

Pos.	Description
	MAGNETIC FILTER
	HYDRAULIC CIRCUIT-BREAKER
	GENERIC BOILER SYSTEM
	CIRCULATOR PWM COMMERCIAL BOILERS AG 85-150 kW
	BUILT-IN BOILER GAS COMBI
1	EXTERNAL UNIT HHP - MONOBLOC 1 -PH OR 3-PH
2	LIGHTBOX
3	SYSTEM INTERFACE
4	LIGHT GATEWAY
5	EXTERNAL PROBE
6	KIT ANTI-FREEZE
9	UNDER FLOOR HEATING
11	CKZ HH WITH ACCESSORIES
14	BY-PASS VALVE

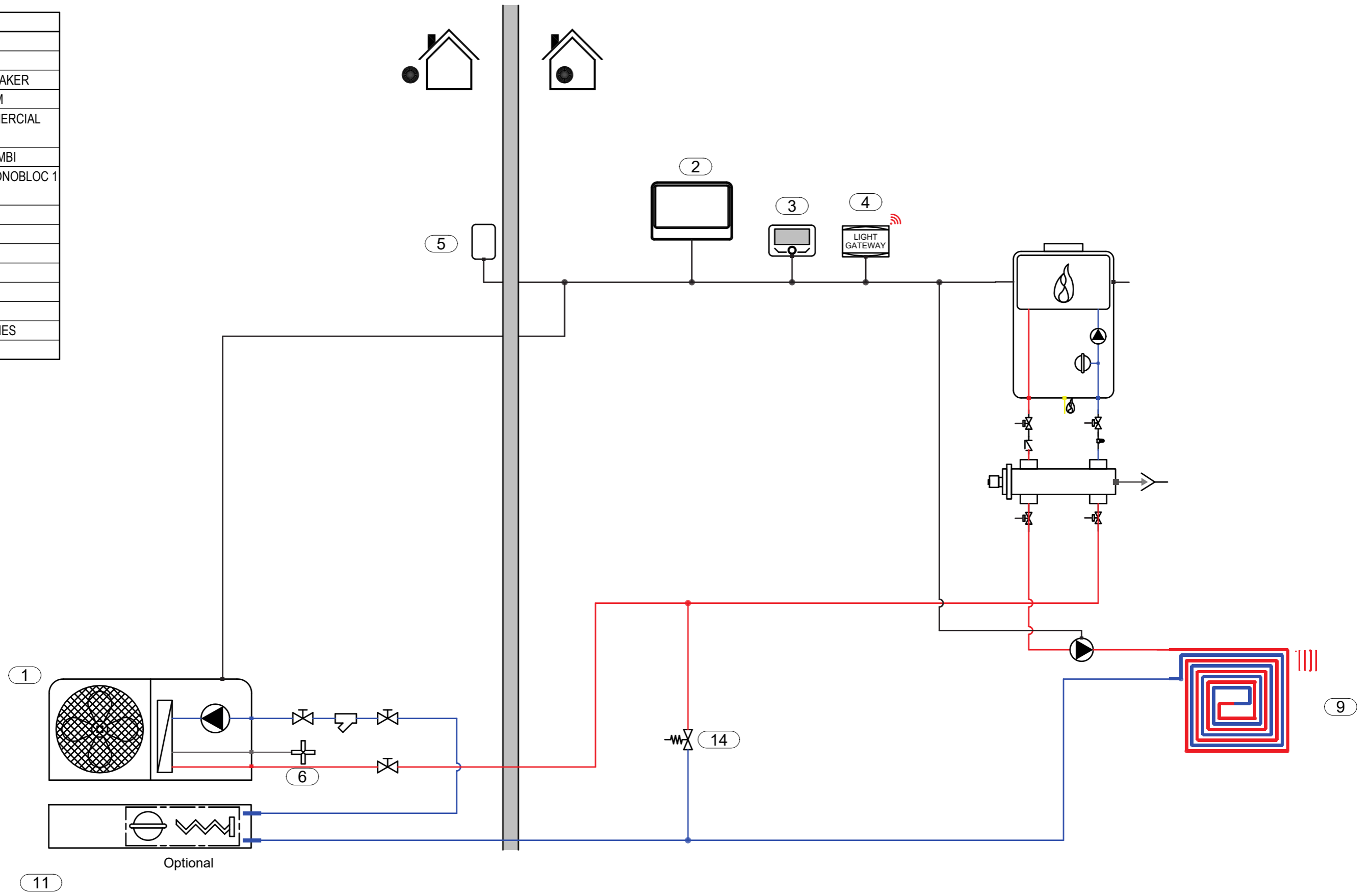

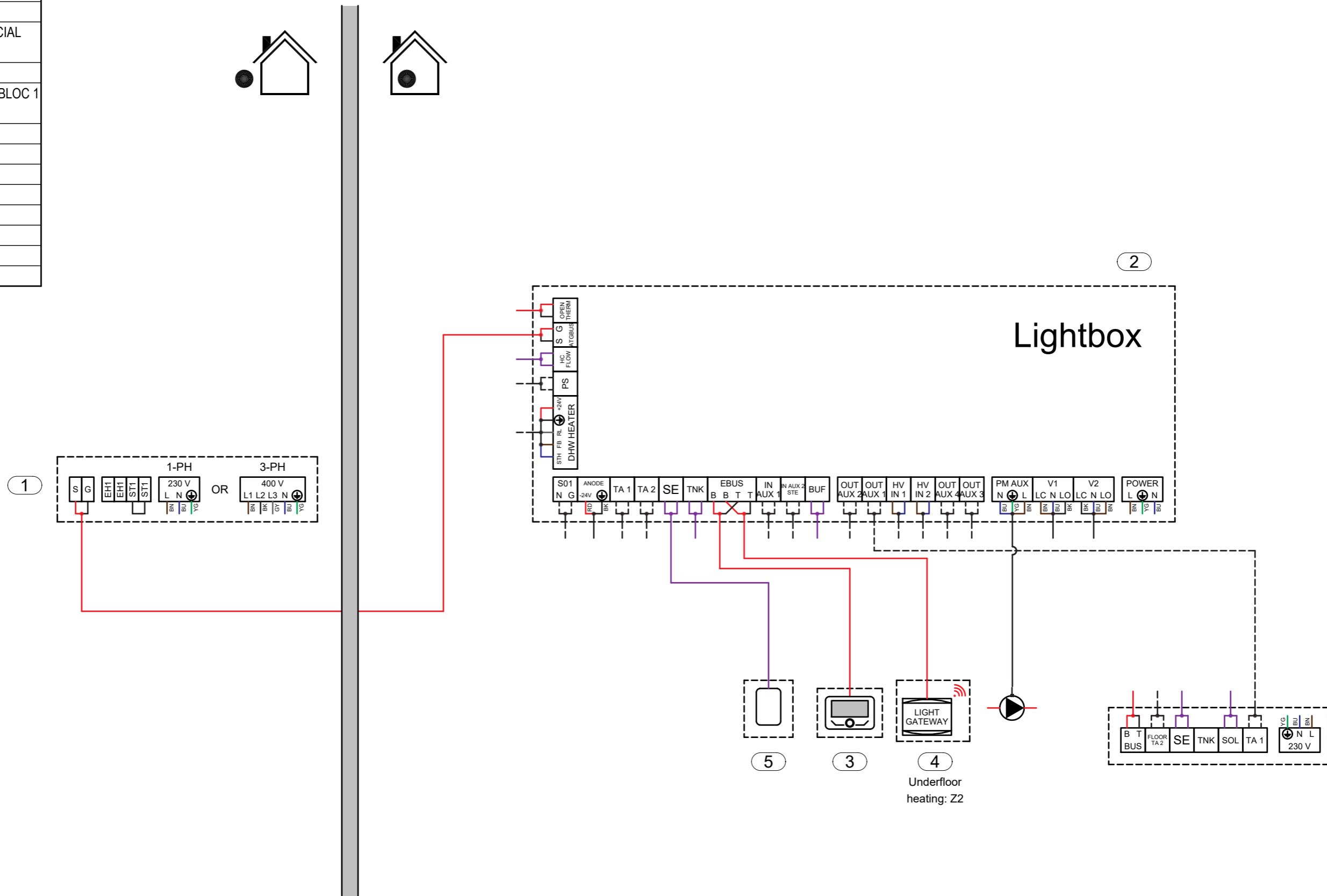

















Pos.	Description
	MAGNETIC FILTER
	HYDRAULIC CIRCUIT-BREAKER
	GENERIC BOILER SYSTEM
	CIRCULATOR PWM COMMERCIAL
	BOILERS AG 85-150 kW
	BUILT-IN BOILER GAS COMBI
1	EXTERNAL UNIT HHP - MONOBLOC 1 -PH OR 3-PH
2	LIGHTBOX
3	SYSTEM INTERFACE
4	LIGHT GATEWAY
5	EXTERNAL PROBE
6	KIT ANTI-FREEZE
9	UNDER FLOOR HEATING
11	CKZ HH WITH ACCESSORIES
14	BY-PASS VALVE

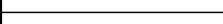

- This schematic is for example only and does not replace design by a qualified technician;
- The final schematic must be prepared respecting all the laws, norms and decrees in force, in order to facilitate a correct installation in compliance with the rule of the art;
- For the proper functioning of all system components, follow the instructions in the design, installation and user manuals provided by the manufacturer;
- This outline may be amended by the Ariston Group at any time without prior notice.

SCHEME Electrical		
DATE 31.8.2023.	REV.	PAGE 2 / 3

SCHEME NAME
EN_014_PCM4.PK_HCD_CD1_BUF.2_1D

Legend	
Hydraulic	
	Hot water
	Cold water
	DHW hot water
	DHW cold water
	DHW mixed water
	DHW recirculaiton water
	Refrigerant fluid
	Gas connection
	Electric connection
Electric	
	BN Brown (L1)
	BU Blue (N)
	YG yellow green (PE)
	BK black (L2)
	GY Grey (L3)
	RD red
	Dry contact
	BUS connection
	Generic signal
	Sensor signal

- This schematic is for example only and does not replace design by a qualified technician;
- The final schematic must be prepared respecting all the laws, norms and decrees in force, in order to facilitate a correct installation in compliance with the rule of the art;
- For the proper functioning of all system components, follow the instructions in the design, installation and user manuals provided by the manufacturer;
- This outline may be amended by the Ariston Group at any time without prior notice.

SCHEME			SCHEME NAME
Legend			EN_014_PCM4.PK_HCD_CD1_BUF.2_1D
DATE	REV.	PAGE	
31.8.2023.		3 / 3	