



 **ARISTON**

NEXT EVO X SFT

**KORISNIČKI PRIRUČNIK
UPUTE ZA POSTAVLJANJE I UPOTREBU**

PROTOČNI PLINSKI GRIJAČ VODE

TOPLA VODA | GRIJANJE | OBNOVLJIVI IZVORI ENERGIJE | KLIMA UREĐAJI

ErP

Korisnički priručnik

| | |
|-----------------------------------|----|
| Oznaka CE..... | 3 |
| Općenito | 4 |
| Sigurnosne odredbe..... | 5 |
| Kontrolna ploča..... | 7 |
| Zaslon..... | 7 |
| Postupak paljenja plamenika | 8 |
| Regulacija temperature vode..... | 8 |
| ECO način..... | 9 |
| Postupak gašenja. | 9 |
| Uvjeti gašenja uređaja..... | 10 |
| Zaštita protiv zamrzavanja..... | 11 |
| Izmjena plina..... | 11 |
| Održavanje..... | 11 |

Upute za postavljanje i održavanje

| | |
|------------------------------------|----|
| (Samo za ovlaštene servisere)..... | 12 |
|------------------------------------|----|

User's manual

| | |
|------------------------------------|----|
| CE labelling | 3 |
| General warnings | 4 |
| Safety regulations..... | 5 |
| Control panel | 7 |
| Display..... | 7 |
| Ignition procedure..... | 8 |
| Water temperature adjustment | 8 |
| ECO mode..... | 9 |
| Switching off procedure | 9 |
| Appliance shut-off conditions..... | 10 |
| Anti-freeze protection | 11 |
| Change gas type | 11 |
| Maintenance..... | 11 |

Installation and servicing instructions

| | |
|--------------------------------------|----|
| (Only for qualified technician)..... | 12 |
|--------------------------------------|----|

Proizvod odgovara direktivi EU 2012/19/EU.

Simbol prekrížene kante za otpatke na uređaju upućuje na to da se proizvod na kraju rada mora zbrinuti odvojeno od uobičajenog kućnih smeća u kućanstvu, a mora se odlagati u centru za odlaganje otpada s namjenskim objektima za električne i elektroničke aparata ili se vraćaju trgovcu prilikom kupnje novog zamjenskog proizvoda. Korisnik je odgovoran za odlaganje proizvoda na kraju životnog vijeka u odgovarajućem centru za odlaganje otpada.

Centar za odlaganje otpada (koji pomoću posebnih postupaka obrade i recikliranja učinkovito rastavlja i raspoložuje uređajem) pomaže očuvanju okoliša recikliranjem materijala od kojeg je proizvod napravljen.

Za daljnje informacije o sustavu odlaganja otpada posjetite lokalni centar za zbrinjavanje otpada ili trgovac od kojeg je proizvod kupljen.



This product conforms to Directive WEEE 2012/19/EU.

The symbol of the crossed waste paper basket on the appliance indicates that at the end of its working life the product should be disposed of separately from normal domestic household rubbish, it must be disposed of at a waste disposal centre with dedicated facilities for electric and electronic appliances or returned to the retailer when a new replacement product is purchased.

The user is responsible for the disposal of the product at the end of its life at an appropriate waste disposal centre.

The waste disposal centre (which using special treatment and recycling processes effectively dismantles and disposes of the appliance) helps to protect the environment by recycling the material from which the product is made.

For further information about waste disposal systems visit your local waste disposal centre or the retailer from which the product was purchased.



Poštovani korisniče,
 Želimo se zahvaliti na odabiru ARISTON plinskog protočnog grijača za vodu. Jamčimo da je naš plinski protočni grijač za vodu tehnički ispravan. Ovaj priručnik daje detaljne upute i preporuke za pravilno postavljanje, uporabu i održavanje.
 Čuvaj priručnik s pažnjom za buduće provjere plina. Naša ARISTON najbliža tehnička služba stoji ti na raspolaganju.

Dear Customer,
 Thank you for choosing an ARISTON gas water heater. We guarantee that your instantaneous water heater is a reliable and technically sound product. This manual provides detailed instructions and recommendations for proper installation, use and maintenance.
 Remember to keep this manual in a safe place for future reference i.e. by the gas meter. Your local ARISTON Servicing Centre is at your complete disposal for all requirements.

UPOZORENJE!

Voda toplija od 50 C može uzrokovati opekline. Uvijek provjerite temperaturu vode prije korištenja.

VAŽNO!

Ako je jedinica postavljena u području s tvrdom vodom (> 200 mg/l) neophodno je postaviti omekšivač vode kako bi smanjili stvaranje kamenca u izmjenjivaču topline. Jamstvo ne pokriva štetu uzrokovanu kamencom.

UPOZORENJE!

Uređaj treba biti aktiviran jedino uz prisustvo vode u izmjenjivaču.

**WARNING!!**

Water with a temperature higher than 50° cause serious burns. Always verify water temperature before use.

¡IMPORTANT!

If the unit is installed in areas with the presence of hard water (> 200 mg / l) is necessary to install a water softener to reduce the precipitation of limestone in the heat exchanger. The warranty does not cover damage caused by the limestone.

WARNING!!

The device must be activated only in presence of water in the exchanger.

Oznaka CE

Znak CE jamči da uređaj odgovara slijedećim odredbama:

- 2016/426/EU plinski uređaji
- 2014/30/EU elektromagnetska kompatibilnost
- 2014/35/EU električna sigurnost
- 2009/125/CE proizvodi vezani uz energiju
- 814/2013 EU propis

CE labelling

The CE mark guarantees that the appliance conforms to the following directives:

- 2016/426/EU relating to gas appliances
- 2014/30/EU relating to electromagnetic compatibility
- 2014/35/EU relating to electrical safety
- 2009/125/CE - Energy related Products
- 813/2013 - Regolamentoo UE

**OVAJ PRIRUČNIK
(UPUTE ZA KORIŠTENJE,
TEHNIČKE UPUTE ZA POSTAVLJANJE I
ODRŽAVANJE) PREDSTAVLJA BITNI I
SASTAVNI DIO PROIZVODA. POTREBNO GA
JE BRIŽLJIVO ČUVATI ZAJEDNO S
UREĐAJEM ČAK I U SLUČAJU PROMJENE
VLASNIKA BOJLERA ILI MJESTA
KORIŠTENJA.
PAŽLJIVO PROČITAJTE UPUTE I NAPOMENE
IZ PRIRUČNIKA JER ĆE VAM ONE PRUŽITI
VAŽNE PODATKE KOJI SE ODOSE NA
SIGURNOST INSTALIRANJA, UPOTREBE I
ODRŽAVANJA.**

Ovaj uređaj služi za proizvodnju tople vode i grijanje u kućanstvu. Mora biti priključen na sustav za grijanje i na vodovodnu mrežu za dobavu tople vode, u skladu sa svojim davanjima i snagom.

Zabranjuje se uporaba u svrhe drugačije od navedenih. Proizvođač ne odgovara za štetu do koje bi moglo doći zbog nepravilne, pogrešne i nerazborite uporabe ili manjkavosti u odnosu na upute koje su dane u ovoj knjižici.

Instalacija, održavanje i bilo koja druga intervencija moraju se vršiti poštivajući važeće propise, i to po uputstvima proizvođača. Neispravno postavljanje može naštetiti osobama, životinjama i stvarima: proizvođač u tom slučaju ne odgovara za štetu. U slučaju kvara i/ili lošeg rada ugastite uređaj, zatvorite dovod plina i ne pokušavajte popravljati uređaj nego se obratite ovlaštenim serviserima. Kod popravaka, koji moraju biti izvedeni od strane ovlaštenih serviseri, koristite isključivo originalne rezervne dijelove. U suprotnom proizvođač se ne smatra odgovornim za bilo kakve nedostatke sigurnosti rada uređaja.

U slučaju održavanja ili drugih radova u neposrednoj blizini kanala, ispušnih plinova ili njihovih dodataka, isključite uređaj stavljanjem vanskog bipolarnog prekidača u poziciju OFF i zatvorite plinski ventil. Kada su radovi završeni, pozovite ovlaštenog serviseri kako bi provjerio ispravnost kanala i uređaja.

Ukoliko će uređaj biti duže vrijeme van funkcije, potrebno je zatvoriti vanjski dotok plina. U slučaju niskih temperatura potrebno je isprazniti uređaj kako bi se izbjeglo smrzavanje. Kada se uređaj isključuje za stalno, osigurajte prisustvo ovlaštenog serviseri.

Isključite aparat i okrenite vanjsku sklopku "OFF" tijekom čišćenja vanjskih dijelova uređaja.

U blizini uređaja nemojte ostavljati niti koristiti zapaljive predmete. Nemojte dopustiti da djeca ili neiskusne osobe koriste aparat bez nadzora.

This book (user's and installation manual) is an integral and essential component of the product.

Must be kept carefully by you and will always accompany the appliance in the event of its sale to another owner or user and / or transfer to another installation.

Carefully read the instructions and warnings contained in this manual as it contain important information about safe installation, operation and maintenance

This appliance is designed to produce hot water for domestic use.

It should be connected to a distribution network for domestic hot water that must be compatible with its performance and power levels.

The use of the appliance for purposes other than those specified is strictly forbidden. The manufacturer cannot be held responsible for any damage caused by improper, incorrect and unreasonable use of the appliance or by the failure to comply with the instructions given in this manual.

Installation, maintenance and all other interventions must be carried out in full conformity with the governing legal regulations and the instructions provided by the manufacturer.

Incorrect installation can harm persons, animals and possessions; the manufacturing company shall not be held responsible for any damage caused as a result.

In the event of a fault and/or malfunction, turn the appliance off, turn off the gas cock and do not attempt to repair it yourself. Contact a qualified professional instead.

Before any maintenance or repair work is performed on the appliance, make sure you have disconnected it from the electricity supply by switching the external bipolar switch to the "OFF" position and removing the fuse.

All repairs, which should only be performed using original spare parts, should be carried out by a qualified professional.

Failure to comply with the above instructions could compromise the safety of the appliance and invalidate all liability on the part of the manufacturer

In the event of any maintenance or other structural work in the immediate vicinity of the ducts or flue gas exhaust devices and their accessories, switch the appliance off by switching the external bipolar switch to the "OFF" position and shutting off the gas control valve.

When the work has been completed, ask a qualified technician to check the efficiency of the ducting and the devices.

If the appliance should be out of use for a prolonged period, it is recommended that the electrical power supply be disconnected and that the external gas cock be closed. If low temperatures are expected, the appliance and system pipe work should be drained in order to prevent frost damage.

When permanently deactivating the appliance, make sure that the operations are carried out by qualified technical professional.

Turn the appliance off and turn the external switch "OFF" to clean the exterior parts of the appliance.

No inflammable items should be left or used in the vicinity of the appliance.

Do not allow children or inexperienced persons to use the appliance without supervision.

Sigurnosne odredbe

Legenda simbola:

Nepoštivanje upozorenja nosi rizik od ozbiljnih, čak i smrtnih posljedica za osobe.



Nepoštivanje upozorenja nosi rizik od oštećenja s teškim posljedicama za predmete, biljke ili životinje.



Ne otvarajte uređaj

Strujni udar zbog kontakta s dijelovima pod naponom.

Opekline zbog dodira s pregrijanim dijelovima ili rane zbog kontakta s prerezanim dijelovima.

Ne pomičite uređaj s mjesta ugradnje



Strujni udar zbog kontakta s dijelovima pod naponom.

Poplave zbog curenja vode uslijed pomicanja cijevi.

Eksplozije, požari ili otrovanja uzrokovana curenjem plina zbog pomicanja cijevi.

Ne oštećujte električni kabel.

Strujni udar zbog kontakta s dijelovima pod naponom.



Ne ostavljajte predmete na uređaju.

Ozljede uslijed pada predmeta s uređaja zbog vibracija.



Oštećenje uređaja ili drugih predmeta ispod njega uzrokovano padom predmeta s uređaja uslijed vibracija.

Ne penjite se na uređaj

Ozljede zbog pada s uređaja.



Oštećenje uređaja ili okolnih predmeta

Ne penjite se na stolice, potpornje ili nestabilne ljestve da biste očistili uređaj.



Ozljede zbog pada ili porezotina uslijed pada

Ne čistite uređaj prije nego što ga ugase, isključite dotok vode i struje.



Strujni udar zbog kontakta s dijelovima pod naponom.

Ne koristite agresivne ili zapaljive insekticide otopine ili kiseline za čišćenje uređaja.



Safety regulations

Key to symbols:

Failure to comply with this warning implies the risk of personal injury, in some circumstances even fatal



Failure to comply with this warning implies the risk of damage, in some circumstances even serious, to property, plants or animals.



Do not perform operations which involve opening the appliance.

Electrocution from live components.

Personal injury caused by burns due to overheated components, or wounds caused by sharp edges or protrusions.



Do not perform operations which involve removing the appliance from its installation space .

Electrocution from live components.

Flooding caused by water leaking from disconnected piping.



Explosions, fires or intoxication caused by gas leaking from disconnected piping.



Do not damage the power supply cable.

Electrocution from live uninsulated wires.

Do not leave anything on top of the appliance.

Personal injury caused by an object falling off the appliance as a result of vibrations.



Damage to the appliance or items underneath it caused by the object falling off as a result of vibrations.



Do not climb onto the appliance.

Personal injury caused by the appliance falling.



Damage to the appliance or any objects underneath it caused by the appliance falling away from its installation space.



Do not climb onto chairs, stools, ladders or unstable supports to clean the appliance.

Personal injury caused by falling from a height or cuts (stepladders shutting accidentally).



Do not attempt to clean the appliance without first switching it off and turning the external switch to the off position.

Oštećenja plastičnih i obojenih dijelova uređaja. 

Ne koristite uređaj za drugu svrhu osim za normalnu primjenu u kućanstvu.

Oštećenje uređaja uslijed prevelikog korištenja.

Šteta od nepropisno obrađenih predmeta.

Neka uređaj ne koriste djeca i neiskusne osobe. 

Oštećenje uređaja zbog nepravilnog korištenja.

U slučaju da osjetite miris paljevine ili dima, ugasisite uređaj, isključite struju, otvorite prozore i pozovite ovlaštenog servisera.

Ozljede uslijed trovanja ili udisanja plina. 

U slučaju da osjetite miris plina, ugasisite uređaj, isključite struju, otvorite prozore i pozovite ovlaštenog servisera.

Eksplozije, požari ili trovanja.





PAŽNJA

Uređaj nije namijenjen za korištenje djeci i osobama sa smanjenim sposobnostima, manjkom iskustva ili znanja, ako nisu u pratnji odgovorne osobe ili ako nisu upoznati s korištenjem uređaja na siguran način i ne razumiju potencijalnu opasnost.

Djeca se ne smiju igrati s uređajem.

Čišćenje i održavanje uređaja ne smiju vršiti djeca bez nadzora.

Electrocution from live components. 
Do not use insecticides, solvents or aggressive detergents to clean the appliance.

Damage to plastic and painted parts. 

Do not use the appliance for any use other than normal domestic use.

Damage to the appliance caused by operation overload. 

Damage caused to objects treated inappropriately.

Do not allow children or inexperienced individuals to operate the appliance.

Damage to the appliance caused by improper use. 

If you detect a smell of burning or smoke coming from the appliance, disconnect it from the electricity supply, turn off the main gas valve, open all windows and call for assistance.

Personal injury caused by burns, smoke inhalation, intoxication. 

If there is a strong smell of gas, turn off the main gas valve, open all windows and call for assistance.

Explosions, fires or intoxication. 

ATTENTION

This appliance can be used by children aged from 8 years and above and person with reduced physical, sensory or mental capabilities or lack of experience and knowledge if they have been given supervision or instruction concerning use of the appliance in a safe way and understand the hazards involved. Children shall not play with the appliance. Cleaning and user maintenance shall not be made by children without supervision.

UPOZORENJE

Ugradnja, prvo uključivanje, održavanje, sukladno uputama trebaju biti izvršeni od strane ovlaštenog servisera. Nepravilna ugradnja može dovesti do ozljeda osoba, životinja ili stvari za koje proizvođač nije odgovoran.

WARNING

Installation, first ignition and maintenance work must be performed by qualified personnel only, in accordance with the instructions provided. Incorrect installation may harm individuals, animals or property; the manufacturer will not be held responsible for any damage caused as a result.

Kontrolna ploča**Control Panel****Legenda:**

1. Zaslón
2. Regulacija temperature (za odabir temperature tople vode)
3. ECO dugme
4. ON/OFF dugme

Legend:

1. Display
2. Temperature Buttons (Used to select hot water delivery temperature).
3. Energy saving button
4. ON/OFF button

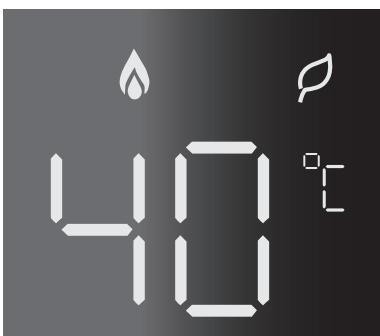
Zaslón**Display**

88 °C

- Temperatura vode (°C)
- Signalizacija kodova greške



Signalizacija prisutnosti plamena
Flame presence signal

Funkcija ECO aktivna
Energy saving signal

Postupak paljenja plamenika

- uvjerite se da je ventil na dijelu za hladnu vodu otvoren
- uvjerite se da je plinski ventil otvoren
- uvjerite se da uređaj dobiva električni napon

Pritisnite dugme ON/OFF "4", zaslon zasvijetli:

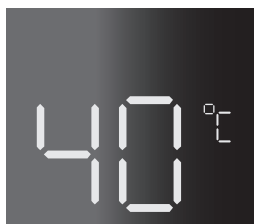

Uređaj je spreman za rad.

Postavljena temperatura je vidljiva na zaslonu.

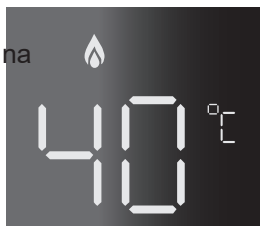

Otvaranjem ventila tople vode, uređaj automatski započinje s radom.

Zaslon pokazuje postavljenu temperaturu i plamen označava paljenje plamenika.

Ignition procedure

- ensure that the valve located on the cold water fitting is open
- ensure that the gas valve is open
- ensure that the device is powered by electric current.

Press ON/OFF button "4", the display lights.

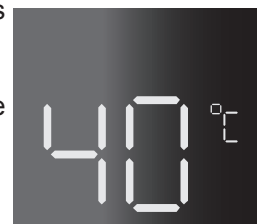

The device is ready to operate
The set temperature is indicated on the display.

By opening a hot water valve, the device automatically starts operating.

The display shows the set temperature and the flame indicates the burner ignition.

**UPOZORENJE!**

Voda toplija od 50 °C može uzrokovati opekline. Uvijek provjerite temperaturu vode prije korištenja.

WARNING!!

Water with a temperature higher than 50° cause serious burns. Always verify water temperature before use.

Napomena: Ako uređaj ne radi, provjerite jesu li ventili za plin i / ili hladnu vodu otvoreni.

Osigurajte da je uređaj električki upogonjen.



Pri zatvaranju ventila, uređaj se automatski isključuje i simbol plamena nestaje sa zaslona.

Note: If the device does not operate, ensure that the gas and/or cold water valves are open.

Ensure that the device is electrically powered.

When closing the valve, the device automatically switches off and the flame symbol disappears from the display.

Regulacija temperature

Pritisnite dugmad 2  ili  da biste postavili temperaturu tople vode.

Na zaslonu će se pokazati nova vrijednost.

**Water temperature adjustment**

Press keys 2  or  to set the hot water temperature.

The new value will be indicated on the display



Moguće je povećati temperaturu do 65 °C





Za podešavanje temperature vode od 35 do 48 °C svaki put pritisnite dugme za promjenu temperature od 1 °C.

Od 48 do 65 °C vidi tablicu.

It's possible to increase the temperature until 65 °C

To set the water temperature from 35 to 48 °C each time press the button the temperature change of 1°C.

From 48 to 65 °C see the table.

| Raspon temperature | Postavljanje ΔT | |
|--------------------|-------------------------|--------------------------------------------------------------------------------------------------------------------------|
| 35-48° C | 1° C | Pritisni dugme  |
| 48-50° C | 2° C | Pritisni  dugme tijekom 5 sec |
| 50-55° C | 5° C | Pritisni "+" dugme |
| 55-60° C | 5° C | Isključi uređaj i pritisni dugme 5 sec  |
| 60-65° C | 5° C | Pritisni dugme  |

Funkcija zaključavanja zbog zaštite djece

Potrebno je isključiti aparat za poništavanje raspona temperature. Nakon toga raspon podešavanja temperature ponovno će biti 35-48 ° C.

Funkcija ECO

Za aktivaciju funkcije ECO, pritisnite dugme 3.

Za povećanje ili smanjenje temperature, pritisnite dugme 2

 ili .





Kada je funkcija ECO aktivna, na na zaslonu se pojavi simbol .



Za izlaz iz ECO funkcije potrebno je pritisnuti dugme 3 kada je uređaj u stanju pripravnosti.

Postupak gašenja

Pritisnite tipku ON / OFF kako biste isključili uređaj. Kako biste potpuno isključili uređaj, okrenite vanjsku električnu sklopku u poziciju OFF. Zatvorite plinski ventil.



| T range | D T setting | |
|----------|-------------|-------------------------------------------------------------------------------------------------------------------------------------------|
| 35-48° C | 1° C | Push  button |
| 48-50° C | 2° C | Push  button for 5 sec |
| 50-55° C | 5° C | Push "+" button |
| 55-60° C | 5° C | Switch OFF the machine and then push  button for 5 sec |
| 60-65° C | 5° C | Push  button |

Child lock function

It's necessary switch OFF the appliance to reset the temperature range. Afterwards the temperature setting range will be again 35-48° C.

ECO mode

To activate the ECO mode press the button 3.

To increase or decrease the temperature press the button 2  or .

When the ECO mode is activated the symbol  appear on the display.



To exit from ECO mode is necessary to push the button 3 when the appliance is in stand-by mode.

Switching off procedure

Press the ON/OFF button, to switch off the appliance. To switch off the device completely, turn the outer electric switch in the off position. Close the gas valve.



Uvjeti za isključivanje uređaja

Uređaj je zaštićen od neispravnosti pomoću unutarnjeg elektroničkog kontrolnog sustava, koji zaustavlja aparat ako je potrebno.

U slučaju gašenja kôd plamena se pojavljuje na zaslonu - vidi tablicu ispod.

Da biste vratili postavke, uključite / isključite uređaj.

**Tablica grešaka**

| Kod Kod | Opis | |
|-----------|----------------------------------------------------|--------------------------------------------------------------------------|
| | Nakon pritiska ON / OFF tipke zaslon se isključuje | - Provjerite električni napon |
| A1 | Nema plamena Greška paljenja | - Provjerite je li plinski ventil otvoren - Pritisnite ON / OFF tipku |

AKO UREĐAJ NE ZAPOČINJE S RADOM ILI SE OPETOVANO ZAUSTAVLJA U RADU, KADA STE SVE PROVJERILI, STAVITE DUGME U POZICIJU OFF, ZATVORITE PLINSKI VENTIL, IZVADITE BATERIJE I KONTAKTIRAJTE OVLAŠTENOG SERVISERA.

UKOLIKO SE GREŠKA NE MOŽE OTKLONITI, NEMOJTE UKLJUČIVATI UREĐAJ.

Zaštita od zamrzavanja

Ako se uređaj instalira na mjestu gdje se cijevi mogu zamrznuti, preporučuje se da ga ispraznite. Postupite na sljedeći način:

- Okrenite vanjski električni prekidač u položaj OFF
- Zatvorite slavinu za plin
- Zatvorite ulazni ventil za hladnu vodu
- Otvorite ventile kućanske vode sve dok se uređaj i cijevi potpuno ne isprazne.

Za ponovno punjenje uređaja, otvorite ulazni ventil za hladnu vodu zajedno s ventilima pitke vode dok voda ne izađe.

Appliance shut-off conditions

The appliance is protected from malfunctions by means of internal checks performed by the electronic P.C.B., which stops the appliance from operating if necessary.

In case of shut-off, the flame a code appear on the display – see table below.

To restore the system, switch ON/OFF the device.

**Error table**

| Error code | Description | |
|------------|-----------------------------------------------------------|-------------------------------------------------------------------|
| | After pressing the ON / OFF button, the display turns off | - Check that the unit is electrically powered. |
| A1 | No flame detected Ignition fault | - Check that the gas cock is open - Press the ON / OFF button. |

IF THE APPLIANCE WON'T START AGAIN OR STOPS REPEATEDLY, ONCE YOU'VE CARRIED OUT THE RELEVANT CHECKS, CLOSE THE GAS VALVE, TURN THE OUTER ELECTRIC SWITCH IN THE OFF POSITION AND CONTACT A QUALIFIED TECHNICIAN.

SHOULD THE ERROR BE NOT ELIMINATED, DO NOT ACTIVATE THE APPLIANCE.

Anti-freeze protection

Should the appliance be installed where pipes are subjected to freezing, it is recommended to empty it. Proceed as indicated below:

- Turn the outer electrical switch to the OFF position
- Close the gas stopcock
- Close the cold water inlet valve
- Open the DHW valves until both the device and pipes are completely emptied.

To fill the device again, open the cold water inlet valve together with DHW valves until the water exits.

Odlaganje i recikliranje uređaja.

Naši proizvodi su dizajnirani i proizvedeni većinom od materijala koji se mogu reciklirati.

Uređaj i njegovi dodaci moraju biti adekvatno odloženi u otpad, razvrstan sukladno korištenim materijalima.

Ambalaža koja se koristi za transport uređaja mora biti zbrinuta od strane instalatera / prodavača.

PAŽNJA!!

Recikliranje i zbrinjavanje uređaja i dodatne opreme moraju biti izvedeni prema propisima

Izmjena plina

Naši grijači rade s metanom ili LPG plinom. Ako ga je neophodno mijenjati, kontaktirajte ovlaštenog servisera ili jedan od naših ovlaštenih servisnih centara.

Održavanje

Potrebno je napraviti održavanje uređaja jednom godišnje od strane ovlaštenog servisera. Pravilno održavanje rezultira ekonomičnim radom uređaja.

Ukoliko ne napravite redovno održavanje uređaja tijekom druge godine korištenja, prestat će vam vrijediti jamstveni list.

Disposal and recycling boiler.

Our products are designed and manufactured for most of the components of recyclable materials.

The boiler and its accessories have to be adequately disposed and the various materials differentiated, where possible.

The packaging used for the transport of the boiler must be disposal by the installer / dealer.

ATTENTION!!

Recycling and disposal of the boiler and the accessories must be made as required by regulations.

Change of gas type

Our instantaneous water heaters are designed to function either with Natural Gas (methane) or L.P.G. gas. If you need to change from one gas to the other, one of our Authorised Service Centres must be contacted to convert the appliance.

Maintenance

Schedule an annual maintenance check-up for the appliance with a competent person. Correct maintenance always results in savings in the cost of running the system.

Failure to arrange an annual service for the appliance will invalidate the second year of the manufacturers guarantee.

Upute za popravak i postavljanje (Samo za ovlaštene servisere)

| | |
|------------------------------------------------------------------------|----|
| Pregled | 13 |
| Savjeti za postavljanje..... | 13 |
| Sigurnosne odredbe..... | 14 |
| Opis proizvoda | 19 |
| Opći pregled..... | 19 |
| Pregled dimenzija..... | 20 |
| Postavljanje | 21 |
| Prije postavljanja uređaja..... | 21 |
| Mjesto postavljanja..... | 22 |
| Minimalne udaljenosti..... | 22 |
| Spajanje plina..... | 23 |
| Spajanje vode..... | 23 |
| Pregled hidrauličnih spojeva..... | 23 |
| Uređaj za prekomjerni tlak..... | 24 |
| Prikaz vodenog kruga..... | 25 |
| Ispuštanje dimnih plinova / Priklučci zausiszraka..... | 26 |
| Tablica duljina kanala za ispuh dima..... | 27 |
| Tipovi kanala usisa zraka/ ispuha dima..... | 27 |
| Električni spojevi..... | 28 |
| Električni prikaz..... | 29 |
| Puštanje u rad | 30 |
| Postupak paljenja..... | 30 |
| Opskrba strujom..... | 30 |
| Punjenje vodenog kruga..... | 30 |
| Opskrba plinom..... | 30 |
| Prvo paljenje..... | 31 |
| Regulacija plina..... | 32 |
| Provjera tlaka..... | 32 |
| Provjera maksimalnog/minimalnog tlaka gorenja..... | 32 |
| Provjera polakog paljenja..... | 33 |
| Tablica plina..... | 34 |
| Izmjena plina..... | 34 |
| Sustavi zaštite uređaja | 35 |
| Tablica kodova grešaka..... | 35 |
| Održavanje | 36 |
| Upute za otvaranje kućišta i provođenje pregleda unutrašnjosti..... | 36 |
| Općenito..... | 37 |
| Proba rada..... | 38 |
| Postupak drenaže..... | 38 |
| Informacije za korisnika..... | 38 |
| Simboli..... | 39 |
| Techničke karakteristike | 40 |
| ErP podaci..... | 41 |
| Karta proizvoda..... | 41 |

Installation and servicing instructions (Only for qualified technician)

| | |
|----------------------------------------------------------------------------------|----|
| Overview | 13 |
| Advice for the installer..... | 13 |
| Safety regulations..... | 14 |
| Product description | 19 |
| Overall view..... | 19 |
| Overall dimensions..... | 20 |
| Installation | 21 |
| Before installing the appliance..... | 21 |
| Installation location..... | 22 |
| Minimum clearances..... | 22 |
| Gas connection..... | 23 |
| Water connection..... | 23 |
| View of hydraulic connections..... | 23 |
| Excessive pressure device..... | 24 |
| Water circuit diagram..... | 25 |
| Flue discharge/Air intake duct connections..... | 26 |
| Table of flue gas exhaust duct lengths..... | 27 |
| Type of air suction/flue gas exhaust ducting..... | 27 |
| Electrical connections..... | 28 |
| Electrical diagram..... | 29 |
| Commissioning | 30 |
| Ignition procedure..... | 30 |
| Electricity supply..... | 30 |
| Filling the hydraulic circuit..... | 30 |
| Gas supply..... | 30 |
| First Ignition..... | 31 |
| Checking the gas settings..... | 32 |
| Supply pressure check..... | 32 |
| Checking the maximum/minimum burner pressure..... | 32 |
| Checking slow ignition power..... | 33 |
| Gas settings table..... | 34 |
| Gas changeover..... | 34 |
| Appliance protection devices | 35 |
| Table summarising error codes..... | 35 |
| Maintenance | 36 |
| Instruction for opening the casing and performing an internal inspection..... | 36 |
| General comments..... | 37 |
| Operational test..... | 38 |
| Draining procedures..... | 38 |
| Information for the user..... | 38 |
| Symbols used on the data plate..... | 39 |
| technical data | 40 |
| ErP Data..... | 41 |
| Product fiche..... | 41 |

Savjeti za postavljanje
POSTAVLJANJE I PRVO PALJENJE
TREBA IZVRŠITI OVLAŠTENI SERVISER,
TE U SKLADU S VAŽEĆIM ZAKONIMA O
JAVNOM ZDRAVSTVU.



Ovaj uređaj služi za proizvodnju tople vode u kućanstvu. Mora biti priključen na vodovodnu mrežu za dobavu tople vode, u skladu sa svojom izvedbom i snagom. Zabranjuje se uporaba u svrhe drugačije od navedenih. Proizvođač ne odgovara za štetu do koje bi moglo doći zbog nepravilne, pogrešne i nerazborite uporabe ili manjkavosti u odnosu na upute koje su dane u ovom priručniku.

Instalacija, održavanje i bilo koja druga intervencija moraju se vršiti poštujući važeće propise, i to po uputstvima proizvođača. Nepravilna ugradnja uzrokovat će ozljede osoba, životinja i stvari za koje proizvođač nije odgovoran.

Uređaj se dostavlja s kartonskom ambalažom, nakon skidanja ambalaže uvjerite se da je uređaj dostavljen u ispravnom stanju, u suprotnom obratite se dostavljaču. Držite sav dostavljeni materijal za pakiranje (spajalice, plastične vrećice, polistirensku pjenu, itd.) izvan doseg djece jer mnogo toga je potencijalno opasno.

U slučaju kvara ili lošeg rada grijača ugasi uređaj, zatvorite plin te se obratite ovlaštenom serviseru. Prije bilo kakvih radova isključite uređaj iz električnog napajanja te stavite vanjski bipolarni prekidač u poziciju OFF i uklonite osigurač.

Sve radove treba obavljati isključivo ovlaštenu serviser, ukoliko se mijenjaju dijelovi, treba koristiti originalne zamjenske dijelove. Nepoštivanje ovih uputa može biti štetno za sigurnost uređaja, te proizvođač nije odgovoran za načinjenu štetu.

U slučaju bilo kakvog održavanja ili drugih konstrukcijskih radova u neposrednoj blizini kanala ili dimnih ispušnih plinova i njihovih dodataka, isključite aparat stavljanjem vanjskog bipolarnog prekidača u poziciju OFF i isključite plinski ventil .

Kada su radovi dovršeni, zamolite ovlaštenog serviser da provjeri ispravnost spojeva i uređaja.

Isključite uređaj i isključite vanjski prekidač stavljanjem u poziciju "OFF" tijekom čišćenja vanjskih dijelova aparata.

Advice for the installer
The installation and first ignition of the
appliance must be performed by qualified
personnel in compliance with current
national regulations regarding installation,
and in conformity with any requirements
established by local authorities and public
health organisations.



This appliance is designed to produce hot water for domestic use.

It should be connected to a distribution network for domestic hot water that must be compatible with its performance and power levels.

The use of the appliance for purposes other than those specified is strictly forbidden. The manufacturer cannot be held responsible for any damage caused by improper, incorrect and unreasonable use of the appliance or by the failure to comply with the instructions given in this manual. Installation, maintenance and all other interventions must be carried out in full conformity with the governing legal regulations and the instructions provided by the manufacturer.

Incorrect installation can harm persons, animals and possessions; the manufacturing company shall not be held responsible for any damage caused as a result.

The appliance is delivered in a carton. Once you have removed all the packaging, make sure the appliance is intact and that no parts are missing. If this is not the case, please contact your supplier.

Keep all packaging material (clips, plastic bags, polystyrene foam, etc.) out of reach of children as it may present a potential hazard.

In the event of a fault and/or malfunction, turn the appliance off, turn off the gas cock and do not attempt to repair it yourself. Contact a qualified professional instead. Before any maintenance or repair work is performed on the appliance, make sure you have disconnected it from the electricity supply by switching the external bipolar switch to the "OFF" position and removing the fuse.

All repairs, which should only be performed using original spare parts, should be carried out by a qualified professional. Failure to comply with the above instructions could compromise the safety of the appliance and invalidate all liability on the part of the manufacturer.

In the event of any maintenance or other structural work in the immediate vicinity of the ducts or flue gas exhaust devices and their accessories, switch the appliance off by switching the external bipolar switch to the "OFF" position and shutting off the gas control valve.

When the work has been completed, ask a qualified technician to check the efficiency of the ducting and the devices.

Turn the appliance off and turn the external switch "OFF" to clean the exterior parts of the appliance.

Čišćenje izvršite krpom uronjenom u vodu sa deterđentom. Ne koristite agresivne deterđente, insekticide ili otrovne proizvode. Ukoliko je uređaj u skladu s aktualnim zakonima, radit će na siguran, ekološki prihvatljiv i štedljiv način. Ukoliko koristite dodatnu opremu, osigurajte da je autentična.

Clean using a cloth dampened with soapy water. Do not use aggressive detergents, insecticides or toxic products. If the appliance is used in full compliance with current legislation, it will operate in a safe, environmentally-friendly and cost-efficient manner. If using kits or optional extras, make sure they are authentic.

UPOZORENJE!

Voda toplija od 50 C može uzrokovati opekline. Uvijek provjerite temperaturu vode prije korištenja.

Warning!!

Water with a temperature higher than 50° cause serious burns. Always verify water temperature before use.

UPOZORENJE!!

Uređaj mogu koristiti djeca u dobi od 8 i više godina i osobe sa smanjenim tjelesnim, senzornim ili mentalnim sposobnostima ili nedostatkom iskustva i znanja ako su pod nadzorom ili su dobili uputu o uporabi uređaja i razumiju uključene opasnosti. Djeca se ne smiju igrati s uređajem. Djeca bez nadzora ne smiju čistiti i održavati uređaj.

WARNING!!

This appliance can be used by children aged from 8 years and above and person with reduced physical, sensory or mental capabilities or lack of experience and knowledge if they have been given supervision or instruction concerning use of the appliance in a safe way and understand the hazards involved. Children shall not play with the appliance. Cleaning and user maintenance shall not be made by children without supervision.

Sigurnosne odredbe

Legenda simbola:

Nepoštivanje upozorenja nosi rizik od ozbiljnih, čak i smrtnih posljedica za osobe. 

Nepoštivanje upozorenja nosi rizik od oštećenja s teškim posljedicama za predmete, biljke ili životinje. 

Postavite uređaj na čvrsti zid nepodložan vibracijama.

Buka tijekom rada.

Tijekom bušenja nemojte oštetiti zid, postojeće instalacije i cijevi. 

Smrtne posljedice uslijed kontakta sa žicama pod naponom. 

Eksplozije, požari ili gušenje uzrokovano curenjem plina iz oštećenih cijevi. 

Oštećenje postojećih instalacija.

Poplave uzrokovane curenjem vode iz oštećenih cijevi.

Izvedite sve električne spojeve pomoću žica odgovarajućeg presjeka. 

Požar uzrokovan pregrijavanjem zbog struje koja prolazi kroz manji kabel. 

Zaštitite cijevi i kablove kako ih ne biste oštetili.

Smrtne posljedice uslijed kontakta sa žicama pod naponom. 

Eksplozije, požari ili gušenje uzrokovano curenjem plina iz oštećenih cijevi.

Oštećenje postojećih instalacija. 

Poplave uzrokovane curenjem vode iz oštećenih cijevi. 

Provjerite jesu li mjesto ugradnje i sustavi na koje se mora spojiti opremu u skladu s važećim propisima.

Safety regulations

Key to symbols:

Failure to comply with this warning implies the risk of personal injury, in some circumstances even fatal 

Failure to comply with this warning implies the risk of damage, in some circumstances even serious, to property, plants or animals. 

Install the appliance on a solid wall which is not subject to vibration.

Noisiness during operation. 

When drilling holes in the wall for installation purposes, take care not to damage any electrical wiring or existing piping.

Electrocution caused by contact with live wires. Explosions, fires or asphyxiation caused by gas leaking from damaged piping. Damage to existing installations. 

Flooding caused by water leaking from damaged piping. 

Perform all electrical connections using wires which have a suitable section.

Fire caused by overheating due to electrical current passing through undersized cables. 

Protect all connection pipes and wires in order to prevent them from being damaged.

Electrocution caused by contact with live wires. Explosions, fires or asphyxiation caused by gas leaking from damaged piping. 

Flooding caused by water leaking from damaged piping. 

Make sure the installation site and any systems to which the appliance must be connected comply with the applicable norms in force.

Electrocution caused by contact with live wires which have been installed incorrectly. 

Damage to the appliance caused by improper operating conditions. 

Smrtne posljedice uslijed kontakta sa žicama pod naponom i nepravilno instaliranima. Oštećenje uređaja zbog nepravilnog rada

Koristite alate i opremu navedene u priručniku. Posebno osigurati da je alat ispravan, te da su držači stabilni i pravilno postavljeni, koristite ih ispravno i pazite da ne padnu s visine, te ih pohranite nakon upotrebe.



Osobne ozljede uzrokovane padom krhotina ili fragmenata, udisanjem prašine, udaraca, posjekotina, uboda, abrazije. Štete na aparatu ili okolnih objekata uzrokovanih padom krhotina, udarce i rezova.



Provjerite da su prijenosne ljestve postavljene na sigurnom, da su primjereno otporne na, da su gazišta netaknuta i da nisu skliska, te da neće biti izmaknute. Osigurajte nečiji nadzor cijelo vrijeme.



Osobne ozljede od pada s visine ili posjekotina (duple ljestve).



Provjerite da su klizne ljestve postavljene na sigurnom, da su pogodno otporne i da su gazišta netaknuta i da nisu skliska, da imaju rukohvate uz ljestve i parapete na odmorištu.

Osobne ozljede od pada s visine. **Osigurajte da tijekom svih radova izvedenih na visini (u pravilu s višim visinama od dva metra), postoje ograde u području rada kako bi se spriječio pad, da je prostor u slučaju pada slobodan od opasnih prepreka, te da je moguće ublažavanje eventualnog pada.**



Osobne ozljede od pada s visine.

Use suitable manual tools and equipment (make sure in particular that the tool is not worn out and that its handle is fixed properly); use them correctly and make sure they do not fall from a height. Replace them once you have finished using them.

Personal injury from the falling splinters or fragments, inhalation of dust, shocks, cuts, pricks and abrasions. Damage to the appliance or surrounding objects caused by falling splinters, knocks and incisions.



Make sure any portable ladders are positioned securely, that they are suitably strong and that the steps are intact and not slippery and do not wobble when someone climbs them. Ensure someone provides supervision at all times.

Personal injury caused by falling from a height or cuts (stepladders shutting accidentally).



Make sure any rolling ladders are positioned securely, that they are suitably strong, that the steps are intact and not slippery and that the ladders are fitted with handrails on either side of the ladder and parapets on the landing.

Personal injury caused by falling from a height.



During all work carried out at a certain height (generally with a difference in height of more than two metres), make sure that parapets are used to surround the work area or that individual harnesses are used to prevent falls. The space where any accidental fall may occur should be free from dangerous obstacles, and any impact upon falling should be cushioned by semi-rigid or deformable surfaces.

Personal injury caused by falling from a height.



Provjerite je li radno mjesto ima odgovarajuće sanitarne uvjete u pogledu rasvjete, aeracija, čvrstoće.

Osobne ozljede uslijed udaraca, padova, itd.



Zaštitite uređaj s odgovarajućim materijalom i područja u blizini radnog mjesta.

Štete na aparatu ili okolnim objektima uzrokovane padom krhotina, udarcima ili porezotinama.



Premještajte aparat s odgovarajućom zaštitom i uz oprez.



Štete na aparatu ili okolnih predmeta od udaraca, udaraca, rezova i drobljenja. Nosite, tijekom obrade, zaštitnu opremu. Zabranjeno je dirati proizvod instaliran bez obuće ili mokrim dijelovima tijela.



Osobne ozljede od strujnog udara, pada krhotina ili fragmenata, udisanje prašine, udaraca, posjekotina, uboda, abrazije i vibracija.



Organizirati pomicanje opreme i predmeta kako bi pokreti bili laki i sigurni, izbjegavajući bilo kakve situacije koje mogu biti predmet neuspjeha ili ozljeda.

Štete na aparatu ili okolnih predmeta od udaraca, udaraca, rezova i drobljenja.



Operacije unutar jedinice moraju se provoditi s oprezom kako bi se izbjegao nagli kontakt s oštrim dijelovima.



Osobne ozljede od posjekotina, uboda, abrazije.

Provjerite sve sigurnosne funkcije te detaljno prekontrolirajte sve prije bilo kakvih radova na uređaju, te se uvjerite u ispravnost rada prije ponovnog uključanja.



Make sure the workplace has suitable hygiene and sanitary conditions in terms of lighting, ventilation and solidity of the structures.

Personal injury caused by knocks, stumbling etc.



Protect the appliance and all areas in the vicinity of the work place using suitable material.

Damage to the appliance or surrounding objects caused by falling splinters, knocks and incisions.



Handle the appliance with suitable protection and with care.

Damage to the appliance or surrounding objects from shocks, knocks, incisions and squashing.



During all work procedures, wear individual protective clothing and equipment.

Personal injury caused by electrocution, falling splinters or fragments, inhalation of dust, shocks, cuts, puncture wounds, abrasions, noise and vibration.



Place all debris and equipment in such a way as to make movement easy and safe, avoiding the formation of any piles which could yield or collapse.

Damage to the appliance or surrounding objects from shocks, knocks, incisions and squashing.



All operations inside the appliance must be performed with the necessary caution in order to avoid abrupt contact with sharp parts.

Personal injury caused by cuts, puncture wounds and abrasions.



Reset all the safety and control functions affected by any work performed on the appliance and make sure they operate correctly before restarting the appliance.

Explosions, fires or asphyxiation caused by gas leaks or an incorrect flue gas exhaust.



Damage or shutdown of the appliance caused by out-of-control operation.





Eksplodije, požari ili gušenje uzrokovani curenjem plina ili neispravnim ispuštom plina. 
 Oštećenja aparata ili blokada zbog nepravilnog rada.

Ispraznite sve komponente koje mogu sadržavati toplu vodu, prije rada na njima. 

Osobne ozljede uzrokovane opeklinama.

Izvršite odstranjivanje kamenca, kako je navedeno u uputama, provjetrite prostoriju, nosite zaštitnu odjeću, ne miješajte različite proizvode, te zaštitite aparat i predmete koji ga okružuju. 

Osobne ozljede kože ili očiju uzrokovane doticajem s kiselinom, inhalacijom ili gutanjem štetnih kemikalija. 

Oštećenja na aparatu ili okolnih objekata zbog korozije uzrokovane kiselinom. 

Ako osjetite miris ili vidite dim udaljite se od uređaja, isključite napajanje, otvorite prozore i kontaktirajte servisera. 

Osobne ozljede uzrokovane opeklinama, udisanja dima, opijenosti.

Before handling, empty all components that may contain hot water, carrying out any bleeding if necessary. 

Personal injury caused by burns.

Descale the components, in accordance with the instructions provided on the safety data sheet of the product used, airing the room, wearing protective clothing, avoid mixing different products, and protect the appliance and surrounding objects.

Personal injury caused by acidic substances coming into contact with skin or eyes; inhaling or swallowing harmful chemical agents. 

Damage to the appliance or surrounding objects due to corrosion caused by acidic substances. 

If you detect a smell of burning or smoke, keep clear of the appliance, disconnect it from the electricity supply, open all windows and contact the technician.

Personal injury caused by burns, smoke inhalation, asphyxiation. 

Općeniti prikaz

Overall view

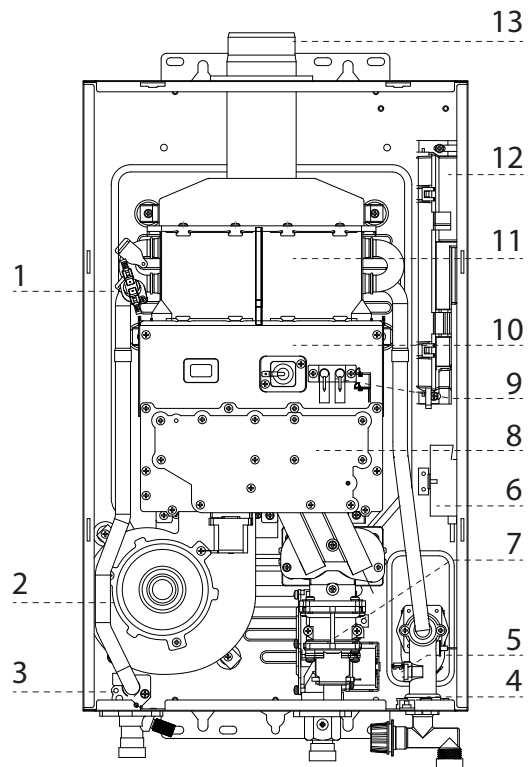
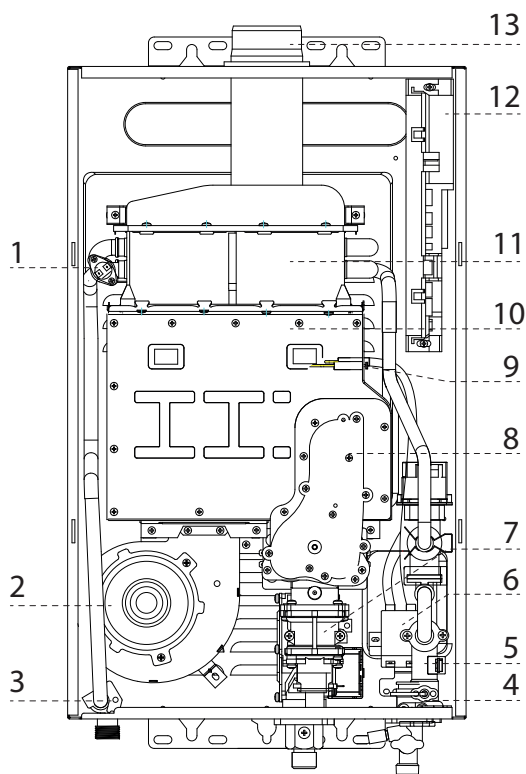

Opis:

1. Termostat pregrijavanja
2. Ventilator
3. Osjetnik temperature izlaza vode
4. Osjetnik temperature ulaza vode
5. Osjetnik protoka vode
6. Generator iskre
7. Plinski ventil
8. Kolektor plina
9. Elektroda za paljenje/detekciju
10. Komora izgaranja
11. Izmjenjivač topline
12. Kontrolna kutija
13. Dimovodni konektor

Legend

1. Overheat thermostat
2. Fan
3. Water outlet temperature probe
4. Water inlet temperature probe
5. Water flow sensor
6. Spark generator
7. Gas valve
8. Gas collector
9. Ignition/Detection electrodes
10. Combustion chamber
11. Heat exchanger
12. Control box
13. Flue connector

Prije postavljanja

Grijač je namijenjen za zagrijavanje vode na temperaturu nižu od temperature vrelišta.

Mora biti spojen na sustav grijanja i na domaću mrežu za vodu i dimenzioniran u skladu s njegovom izvedbom, te za njegovu snagu.

Prije spajanja grijača:

- pažljivo operite cijevi uređaja kako bi se uklonile preostala prljavština koja bi mogla ugroziti pravilan rad grijača;
- uvjerite se u pretpostavke grijača za rad s dostupnim plinom (pročitajte na etiketi ambalaže i na pločici s karakteristikama);
- provjerite da dimnjak nije sužen i da u njega nije spojen ispuh drugih uređaja, osim ako je dizajniran da služi više korisnika, u skladu s odredbama važećih propisa;
- provjerite jesu li, u slučaju spajanja na postojeće dimne kanale, besprijekorno čisti i ne sadrže prljavštine, moguće je da iste mogu ometati prolaz dimnih plinova, što uzrokuje opasnost;
- provjerite je li, u slučaju montaže na neprikladnim dimnim kanalima, da su kanalizirani;
- u prisustvu vode s posebno visokom tvrdoćom, imat ćete rizik od kamenca što rezultira smanjenom učinkovitošću komponenti uređaja.

Uređaji tipa C, s komorama za izgaranje i krugovima dotoka zraka koji su u potpunosti zapečaćeni od vanjskog zraka, nemaju ograničenja u pogledu ventilacije i veličine prostorije u kojoj su ugrađeni.

Kako se normalan rad uređaja ne bi ugrozio, mjesto na kojemu je postavljen mora biti prikladno s obzirom na temperaturu pogonske granične vrijednosti, a uređaj treba zaštititi tako da ne dolazi u izravni kontakt s atmosferskim sredstvima.

Uređaj treba postaviti na čvrstom, nezapaljivom, nepomičnom zidu kojem se ne može prići za stražnje strane.

Kada pripremate prostor za postavljanje, trebaju se poštivati minimalne udaljenosti (koje osiguravaju da se različitim dijelovima uređaja može prići nakon postavljanja).

Before installing the appliance

The appliance heats water to a temperature below boiling. It should be connected to a domestic water mains supply, that must correspond in size to the performance and its power of the appliance.

Before connecting the appliance, it is first necessary to perform the following operations:

- Carefully wash the system piping in order to remove any screw thread or welding residues, or any dirt which might prevent the appliances from operating correctly.
- Make sure that the appliance is set up for operation with the type of gas available (read the information on the packaging label and on the boiler data plate).
- Make sure that there are no obstacles inside flue exhaust and that it does not contain any discharge from other appliances, unless the flue is meant to serve more than one user (in accordance with current legal requirements).
- Where there is already a connection to existing flue exhausts, check that these exhausts have been perfectly cleaned and are without residues, because any disconnection could obstruct the passage of fumes and create potentially dangerous situations.
- Make sure that, where unsuitable flue exhausts are attached, they have been ducted.
- In areas with particularly hard water, limescale may build up on the components inside the appliance and reduce its overall efficiency.

C-type appliance, with combustion chambers and air supply circuits which are completely sealed from the air outside, do not have any limitations concerning the ventilation and size of the room in which they are installed. So that the normal operation of the appliance is not compromised, the place in which it is installed must be suitable with regard to the operating limit temperature value and the appliance should be protected so that it does not come into direct contact with atmospheric agents.

The appliance must be installed on a solid, non-combustible, permanent wall to prevent access from the rear.

When creating a space for the boiler, the minimum distances (which ensure that various parts of the appliance may be accessed after it has been installed) should be respected.

UPOZORENJE!

NE OSTAVLJAJTE ZAPALJIVE OBJEKTE U BLIZINI UREĐAJA. OSIGURAJTE DA JE MJESTO POSTAVLJANJE I BILO KOJI SUSTAV NA KOJI SPAJATE UREĐAJ POTPUNO U SKLADU S VAŽEĆIM ZAKONIMA. UKOLIKO SU PRAŠINA I/ILI AGRESIVNI PARE PRISUTNE U PROSTORIJI GDJE POSTAVLJATE UREĐAJ, UREĐAJ MORA KORISTITI NEOVISAN IZVOR ZRAKA IZVAN TE PROSTORIJE.

UPOZORENJE!

POSTAVLJANJE I PRVO PALJENJE UREĐAJA TREBAJU BITI IZVŠENI OD STRANE OVLAŠTENOG SERVISERA SUKLADNO VAŽEĆIM NACIONALNIM ZAKONIMA VEZANIMA UZ POSTAVLJANJE, TE SUKLADNO LOKALNIM ZDRAVSTVENIM ODREDBAMA.

WARNING

No inflammable items should be left in the vicinity of the appliance. Make sure the installation site and any systems to which the appliance must be connected are fully compliant with the current applicable legislation. If dust and/or aggressive vapours are present in the room in which it is to be installed, the appliance must operate independently of the air inside the room.

WARNING

The installation and first ignition of the appliance must be performed by qualified personnel in compliance with current national regulations regarding installation, and in conformity with any requirements established by local authorities and public health organisations.

Mjesto postavljanja

Prije odabira mjesta postavljanje uređaja proučite važeće zakone.

Uređaj ne smije biti postavljen u blizini izvora grijanja. Ne postavljajte uređaj u okolini gdje temperatura dostiže 0 stupnjeva.

Za postavljanje unutar namještaja, uzmite u obzir, da je maksimalna temperatura plašta uređaja niža od 85 stupnjeva i da se trebaju poštivati tražene minimalne udaljenosti.

Installation location

Observe the regulations in force, when deciding where to install the device.

The device must not be installed near heat sources Do not install the device in environments where temperatures may reach 0°C

For installation inside furniture, consider that the maximum temperature of the device jacket is lower than 85°C and distances required for maintenance must be respected.

Minimalne udaljenosti

Kako bi se omogućio olakšan pristup uređaju tijekom održavanja.

Uređaj treba biti postavljen sukladno udaljenostima navedenima dolje.

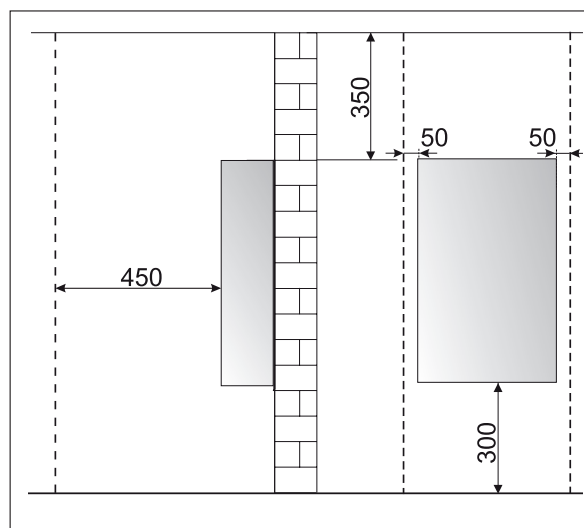
**Minimum clearances**

In order to allow easy access to the appliance for maintenance operations.

The appliance must be installed in accordance with the clearances stated below.

Spajanje plina

Uređaj je dizajniran za korištenje plinova koji pripadaju kategorijama kako je prikazano u donjoj tablici:

| ZEMLJA | MODEL | KATEGORIJA |
|--------|----------------------------------------|------------|
| | NEXT EVO X 11 SFT NEXT EVO X 16 SFT | 2H3B/P |

Osigurajte, sukladno naljepnicama na uređaju i podacima na pločici uređaja, da je uređaj u previđenoj zemlji, te da kategorija plina za koju je uređaj dizajniran odgovara dostupnim kategorijama u zemlji primjene.

Cijevi za opskrbu plinom moraju se izraditi i mjeriti u skladu s posebnim zakonskim zahtjevima i u skladu s maksimalnom snagom uređaja. Također, provjerite je li ventil za zatvaranje pravilne veličine i je li pravilno spojen. Prije izvođenja instalacije preporučuje se temeljito čišćenje cijevi za plin radi uklanjanja ostataka koji bi mogli spriječiti pravilan rad uređaja.

Provjerite odgovara li isporučeni plin tipu plina za koji je napravljen uređaj (pogledajte podatkovnu pločicu koja se nalazi na samom uređaju).

Također je važno provjeriti je li pritisak plina (metana ili LPG) koji koristite za napajanje uređaja prikladan, jer ako je nedostatan, snaga generatora može biti smanjena, što uzrokuje neugodnosti korisniku.

Spajanje vode

Ilustracija prikazuje priključke za vodu i plin uređaja.

Provjerite da maksimalni tlak vode ne prelazi 8 bara; Ako da, potrebno je instalirati ventil za smanjenje tlaka.

Osigurajte da minimalni pritisak ne pada ispod 2,2 bara.

Prikaz hidrauličnih spojeva

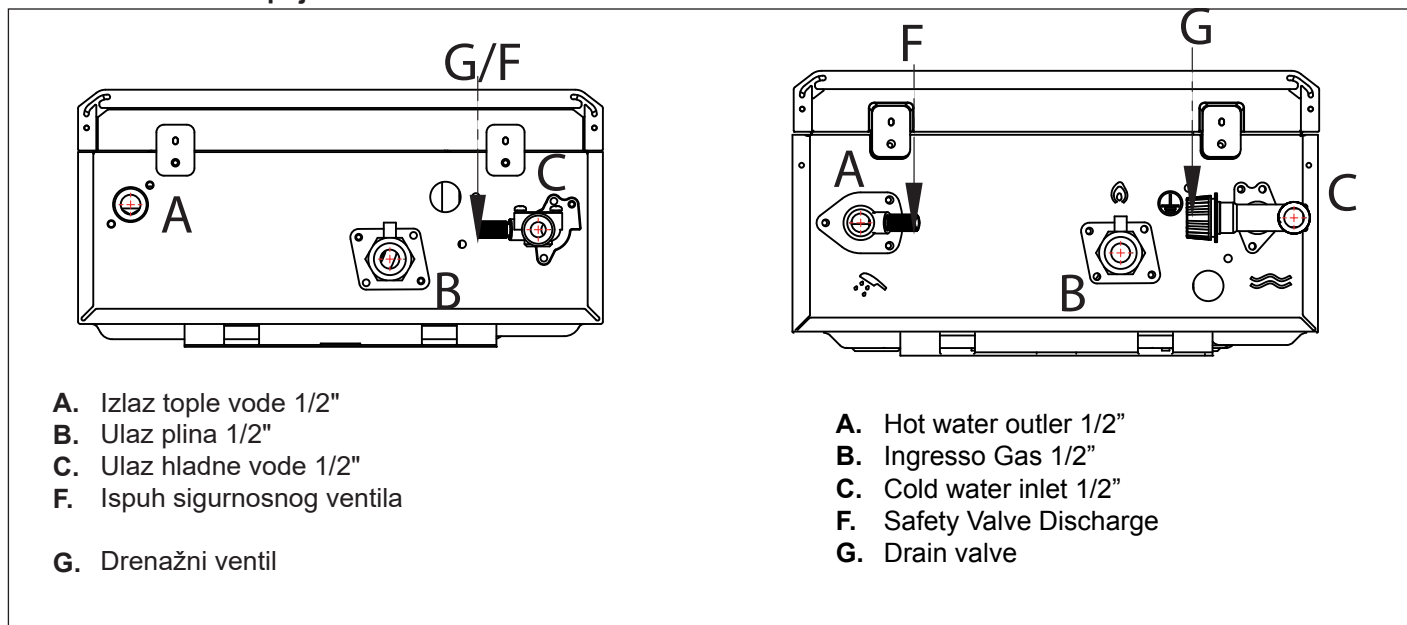

Gas connection

The appliance was designed to use gases belonging to the categories as shown in the following table.

| COUNTRY | MODEL | CATEGORIES |
|---------|----------------------------------------|------------|
| | NEXT EVO X 11 SFT NEXT EVO X 16 SFT | 2H3B/P |

Make sure, using the labels on the packaging and the data plate on the appliance itself, that the appliance is in the correct country and that the gas category for which the appliance was designed corresponds to one of the categories available in the country where it will be used.

The gas supply piping must be created and measured out in compliance with specific legal requirements and in accordance with the maximum power of the appliance; you should also make sure that the shut-off valve is the right size and that it is connected correctly.

Before carrying out the installation, it is recommended that the fuel pipes are cleaned thoroughly in order to remove any residues which could prevent the appliance from operating correctly.

Check that the supplied gas corresponds to the type of gas for which the appliance was designed (see the data plate located on the appliance itself).

It is also important to check that the pressure of the gas (methane or LPG) you will be using to feed the appliance is suitable, because if it is insufficient the power of the generator may be reduced, causing inconvenience for the user.

Water connection

The illustration shows the connections for the water and gas attachments of the appliance.

Check that the maximum water mains pressure does not exceed 8 bar; if it does, a pressure reducing valve must be installed.

Ensure that the minimum pressure is not lower than 2,2 mbar.

View of the hydraulic Connections

Uređaj je opremljen s G filterom koji se nalazi na ulazu hladne vode. Povremeno očistite hidraulični sustav, ukoliko su prisutne nečistoće.

VAŽNO!

**NEMOJTE UKLJUČIVATI UREĐAJ
BEZ FILTRA!**

VAŽNO!

**UKOLIKO JE UREĐAJ POSTAVLJEN U
PODRUČJU S TVRDOM VODOM (> 200
MG/L) NEOPHODNO JE POSTAVLJANJE
OMEKŠIVAČA VODE KAKO BI SE
SMANJILO STVARANJE KAMENCA U
IZMJENJIVAČU TOPLINE. JAMSTVO NE
POKRIVA ŠTETU NASTALU ZBOG
KAMENCA.**

The device is equipped with a filter “G”, located on the cold water entrance. Periodically clean the hydraulic system, if dirt is present.

¡IMPORTANT!

**DO NOT ACTIVATE THE DEVICE WITHOUT
THE FILTER.**

¡IMPORTANT!

**IF THE UNIT IS INSTALLED IN AREAS
WITH THE PRESENCE OF HARD WATER
(> 200 MG / L) IS NECESSARY TO INSTALL
A WATER SOFTENER TO REDUCE THE
PRECIPITATION OF LIMESTONE IN THE
HEAT EXCHANGER.**

**THE WARRANTY DOES NOT COVER
DAMAGE CAUSED BY THE LIMESTONE.**

Uređaj za prekomjerni tlak

Uređaj za prekomjerni tlak mora biti povezan s drenažnim sifonom koji se vizualno može provjeriti kako bi se spriječilo da postupci održavanja nanose štetu ljudima, životinjama ili imovini (proizvođač neće biti odgovoran za takvu štetu).

Excessive pressure device

The excessive pressure device outlet must be connected to a drainage siphon which can be checked visually in order to prevent maintenance procedures causing harm to people, animals or property (the manufacturer shall not be held responsible for any such damage).

Prikaz vodenog kruga

Water circuit diagram

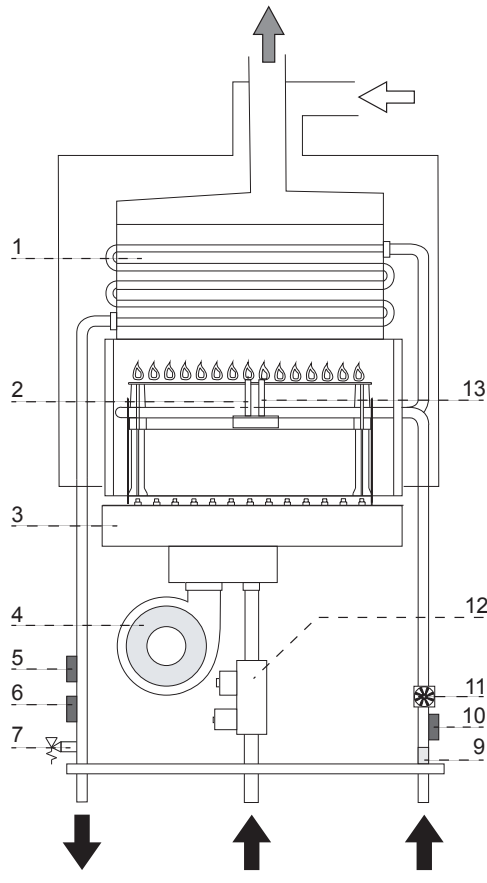

Opis

- 1. Izmjenjivač topline
- 2. Elektroda detekcije
- 3. Plamenik
- 4. Ventilator
- 5. Osjetnik temperature vode
- 6. Termostat pregrijavanja
- 7. Sigurnosni ventil
- 9. Filter ulaza hladne vode
- 10. Osjetnik ulaza hladne vode
- 11. Prekidač vodenog protoka
- 12. Plinski ventil
- 13. Elektroda paljenja

Legend

- 1. Heat exchanger
- 2. Detection Electrode
- 3. Burner
- 4. Fan
- 5. Outgoing water temperature sensor
- 6. Overheat thermostat
- 7. Safety valve
- 9. Cold water inlet filter
- 10. Inlet water temperature probe
- 11. Water flow switch
- 12. Gas valve
- 13. Ignition electrode

Ispuštanje dimnih plinova / Priklučci za usis zraka

Instalacija cjevovoda za usis / ispuh mora biti u skladu s važećim propisima i uputama proizvođača

Uređaj je konstruiran za rad u C modu (uvlačenjem zraka izvana).

Prilikom ugradnje ispušnog sustava budite oprezni pri rukovanju brtvama, kako biste izbjegli curenje dimnih plinova u krug zraka.

Vodonepropusni cjevovod mora imati nagib od 3% kako bi se izbjegao stvaranje kondenzata. Pri implementaciji koaksijalnih sustava usisavanja / ispuštanja obavezna je upotreba originalne opreme.

Kanali za ispuštanje dimnih plinova ne smiju biti u dodiru s ili postavljeni blizu zapaljivih materijala i ne smiju priči konstrukciji ili zidovima izrađenim od zapaljivih materijala.

Spoj cijevi za ispuštanje dimnih plinova treba biti izrađen pomoću muško/ženskog spoja i brtve.

Spojjevi moraju uvijek biti postavljeni tako da idu protiv smjera strujanja kondenzata.

Za metode proračuna, ekvivalentne duljinske vrijednosti i primjere ugradnje upućujemo vas na katalog opreme za dimne plinove.

Spojjevi za spajanje ventila za usis / ispuh isporučuju se odvojeno od uređaja, prema različitim instalacijskim rješenjima. Pažljivo pročitajte upute u kompletu.

Ako se u cjevovodu pojavi bilo kakav gubitak tlaka, molimo pogledajte katalog opreme za dimne plinove.

Prilikom postupka dimenzioniranja mora se imati na umu dodatan otpor.

Za metode proračuna, ekvivalentne duljinske vrijednosti i primjere ugradnje upućujemo vas na katalog opreme za dimne plinove.

UPOZORENJE!

OSIGURAJTE DA ISPUH DIMA I KANALI VENTILACIJE BUDU PROHODNI. UVJERITE SE DA NE DOLAZI DO CURENJA U KANALU ISPUHA DIMA.

**Flue discharge/Air intake duct connections**

Intake/discharge flue duct installation must be in compliance with the regulation in force and instructions provided by the manufacturer

The appliance is designed to operate in C mode (by drawing air from outside).

When installing an exhaust system be careful when handling the seals, in order to avoid flue gas leaking into the air circuit.

Horizontally-installed piping must have a downward incline of 3% so as to avoid the build-up of condensate.

When implementing coaxial suction/exhaust systems the use of authentic accessories is obligatory.

The flue gas exhaust ducting must not be in contact with or placed near flammable materials, and must not cross building structures or walls made using flammable material.

The flue gas exhaust ducting joint should be created using a male/female coupling and a seal.

Couplings should always be arranged so that they go against the direction of the condensate flow.

For the calculation method, equivalent length values and installation examples please refer to the gas flue accessories catalogue.

The suction/exhaust ducting connection kits are supplied separately from the appliance, according to different installation solutions. Carefully read the instructions in the kit.

If there is any loss of pressure in the piping, please refer to the gas flue accessories catalogue. Supplementary resistance must be borne in mind during the sizing process mentioned above.

For the calculation method, equivalent length values and installation examples please refer to the gas flue accessories catalogue.

WARNING

MAKE SURE THAT THE FLUE GAS EXHAUST AND VENTILATION DUCTING ARE NOT OBSTRUCTED.

MAKE SURE THAT THERE ARE NO LEAKS ALONG THE FLUE GAS EXHAUST DUCTING.

The appliance is set up for connection to a coaxial suction and flue gas exhaust ducting system (60/100).

The appliance is set up for connection to a 60/100 coaxial air intake and flue gas exhaust ducting system. For split types of suction and exhaust, using the specified adapter.



Uređaj je postavljen za spajanje na koaksijalni sustav usisavanja i ispušnih plinova (60/100).

Uređaj je postavljen za spajanje na 60/100 koaksijalni usisnik zraka i dimovodni kanalizacijski kanal. Za podijeljene vrste usisavanja i ispuha, pomoću navedenog adaptera.

Tablica dužina ispuha dimnih kanala

Table of flue gas exhaust duct lengths

| Tip Type | | Maksimalna ekstenzija ispuha zraka (m) Maximum Extension Exhaust-air (m) | | Promjer cijevi Pipes diameter (mm) |
|-----------------------------------------|-----|-----------------------------------------------------------------------------|-------|------------------------------------------|
| | | NEXT EVO X SFT 11/16 | | |
| | | MIN | MAX | |
| Koaksijalni sustav Coaxial system | C13 | 0,6 | 8 | ø 60/100 |
| | C33 | | | |
| Sustav duple cijevi Twin-pipe System | C13 | S1 = S2 | | ø 80/80 |
| | C33 | 0,6 = 0,6 | 8 = 8 | |

S1 = usis zraka - S2 = ispuh dima

S1 = Air intake S2 = Flue gas exhaust

Vrsta usisa zraka / ispuha dimnih plinova

Type of air suction/flue gas exhaust ducting

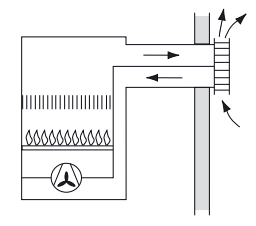
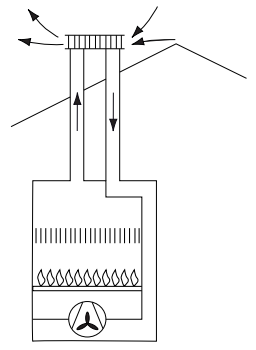
| Usis zraka izvana | | |
|-------------------|-----------------------------------------------------------------------------------------------------|-------------------------------------------------------------------------------------|
| C13 | Ispuh dimnih plinova i usis zraka kroz vanjski zid u istom rasponu tlaka |  |
| C33 | Ispuštanje dimnih plinova i usisni zrak s vanjske strane s krovnim terminalom u istom rasponu tlaka |  |

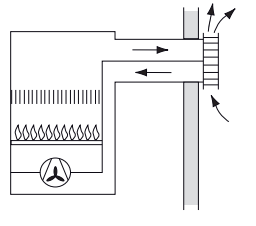
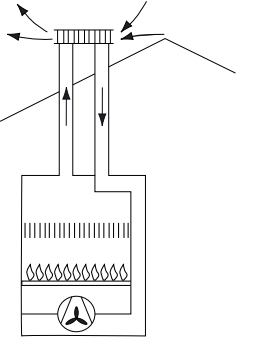
| Combustion air intake from outside | | |
|------------------------------------|-----------------------------------------------------------------------------------------------------|---------------------------------------------------------------------------------------|
| C13 | Flue gas exhaust and air suction duct through external wall in the same range of pressure |  |
| C33 | Flue gas exhaust and air suction duct from outside with roof terminal in the same range of pressure |  |

UPOZORENJE!

Prije izvođenja bilo kakvih radova na uređaju prvo ga isključite iz struje koristeći vanjski bipolarni prekidač.

**Električni spojevi**

Za veću sigurnost zatražite od ovlaštenog servisera da provede temeljitu provjeru električnog sustava. Proizvođač nije odgovoran za bilo kakvu štetu uzrokovanu nedostatkom prikladnog sustava za uzemljenje ili neispravnim napajanjem. Provjerite je li sustav u stanju izdržati maksimalnu snagu koju uređaj apsorbira (to je naznačeno na pločici uređaja). Provjerite je li presjek žice prikladan i ne manji od 0,75 mm². Uređaj mora biti spojen na učinkoviti sustav uzemljenja kako bi pravilno radio. Kabel za napajanje mora biti spojen na mrežu od 230V-50Hz, gdje se poštuju L-N polovi i zemaljska veza.

WARNING

Before performing any work on the appliance, first disconnect it from the electrical power supply using the external bipolar switch.

**Electrical connections**

For increased safety, ask a qualified technician to perform a thorough check of the electrical system. The manufacturer is not responsible for any damage caused by the lack of a suitable earthing system or by the malfunctioning of the electricity mains supply. Make sure that the system is able to withstand the maximum power absorbed by the appliance (this is indicated on the appliance data plate). Check that the section of the wires is suitable and is not less 0,75 mm². The appliance must be connected to an efficient earthing system if it is to operate correctly. The power supply cable must be connected to a 230V-50Hz network, where the L-N poles and the earth connection are all respected.

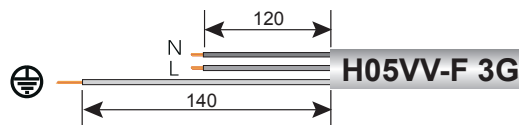
**Važno!**

Spajanje na mrežni napon mora se izvršiti pomoću fiksne veze (ne s mobilnim utikačem) i bipolarnim prekidačem s minimalnim kontaktnim otvorom od 3 mm koji mora odgovarati.

Korištenje multiutičnica, produžnih kabela ili adaptera strogo je zabranjeno. Strogo je zabranjeno koristiti cjevovode od vode, grijanja i plinskih sustava za spajanje uzemljenja uređaja. Uređaj nije zaštićen od utjecaja munje. Ako se osigurači za napajanje moraju zamijeniti, koristite 3,15A brzi osigurač.

Important!

Connection to the electricity mains supply must be performed using a fixed connection (not with a mobile plug) and a bipolar switch with a minimum contact opening of 3 mm must be fitted.

The use of multiplugs, extension leads or adapters is strictly prohibited. It is strictly forbidden to use the piping from the hydraulic, heating and gas systems for the appliance earthing connection. The appliance is not protected against the effects caused by lightning. If the mains fuses need to be replaced, use 3.15A rapid fuses.

Električni prikaz

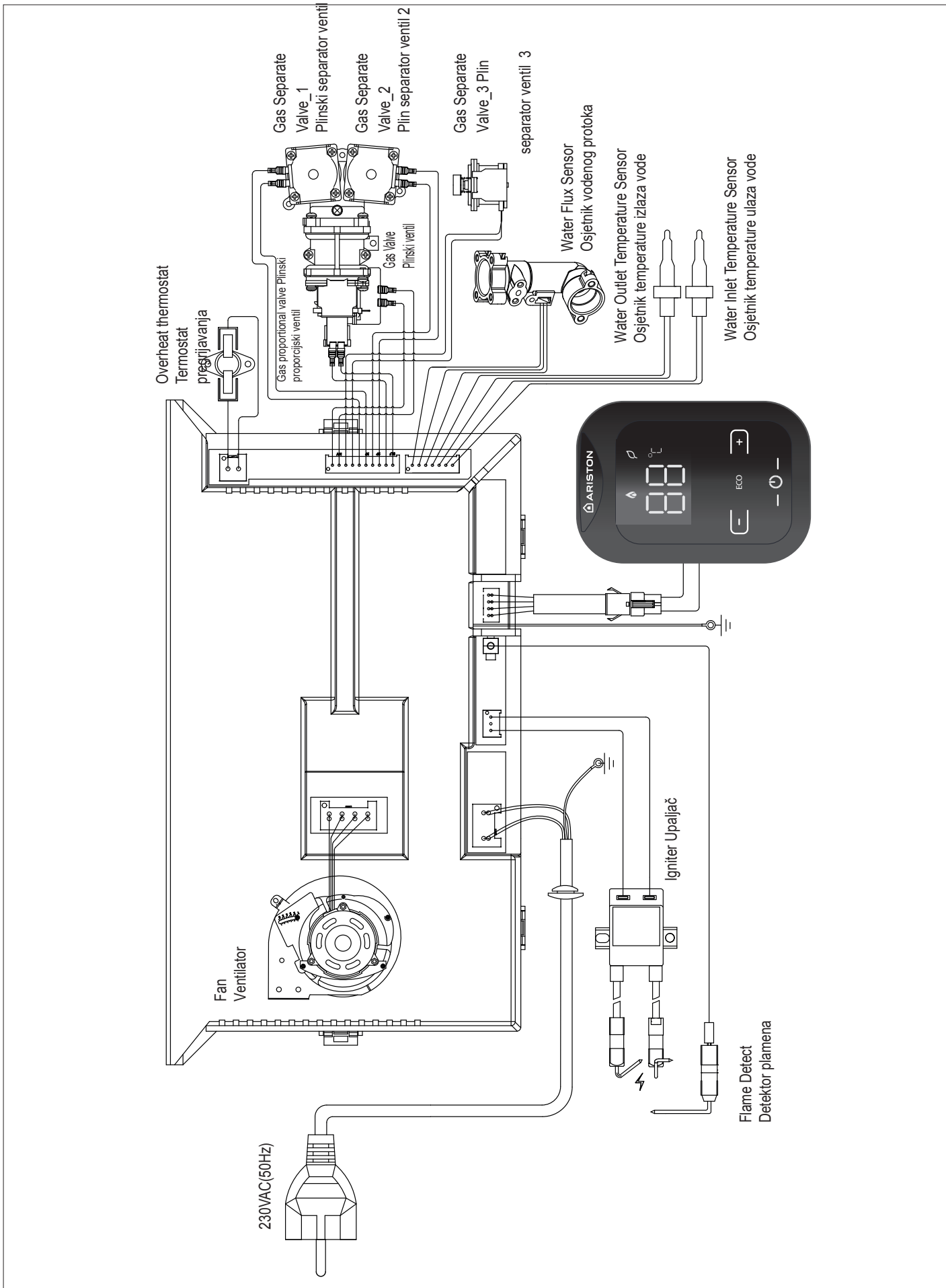

Postupak paljenja

Pritisnite tipku ON / OFF na upravljačkoj ploči za prikaz temperature.

Za podešavanje temperature pogledajte odlomak Korisnički priručnik.

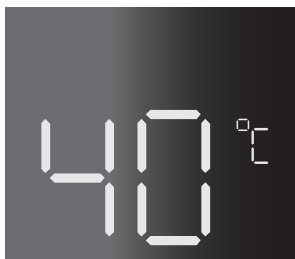
**Ignition procedure**

Press the ON/OFF key placed on the control panel, to display the set temperature.

For temperature adjustments see the User Manual paragraph.

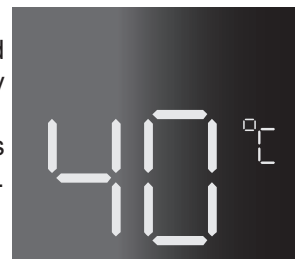
**Predradnje**

Kako bi se jamčila sigurnost i pravilan rad uređaja, uređaj mora biti pripremljen za rad od strane ovlaštenog servisera koji posjeduje vještine propisane zakonom.

Initial procedures

To guarantee safety and the correct operation of the appliance, the appliance must be prepared for operation by a qualified technician who possesses the skills which are required by law.

Električno napajanje

- Provjerite jesu li napon i frekvencija opskrbe električnom energijom u skladu s podacima prikazanim na pločici s podacima uređaja;
- Provjerite je li veza uzemljenja učinkovita.

Electricity supply

- Check that the voltage and frequency of the electricity supply correspond to the data shown on the appliance data plate;
- Make sure that the earthing connection is efficient.

Punjenje vodenog krupa

Postupite kako slijedi:

- **Postepeno** otvorite ventil na ulazu hladne vode
- Otvorite ventil tople kućanske vode

Filling the hydraulic circuit

Proceed in the following manner:

- **Gradually** open the valve located on the cold inlet;
- open a D.H.W. tap.

UPOZORENJE !

NE KORISTITE UREĐAJ AKO NIJE NAPUNJEN VODOM.

**WARNING!!**

DO NOT USE THE APPLIANCE WITHOUT WATER.

**Dotok plina**

Postupite kako slijedi:

- Osigurajte da glavna opskrba plinom koristi istu vrstu plina kao što je navedeno na pločici s podacima uređaja;
- Otvoriti sva vrata i prozore;
- Provjerite da u sobi nema iskre ili otvorenog plamena;
- Provjerite da sustav ne propušta plin pomoću odsječenog ventila unutar uređaja, koji bi trebao biti zatvoren te otvoren dok je plinski ventil isključen. Mjerač ne smije pokazivati tragove unutar 10 minuta.

Gas supply

Proceed in the following manner:

- Make sure that the main gas supply uses the same type of gas as indicated on the appliance data plate;
- Open all doors and windows;
- Make sure there are no sparks or naked flames in the room;
- Make sure that the system does not leak fuel using a cut-off valve inside the appliance itself which should be closed and then opened while the gas valve is disabled. The meter must not show any signs of gas being used for 10 minutes.

Prvo paljenje

Prvo paljenje mora biti izvršeno od strane OVLAŠTENOG SERVISERA.

1. Uvjerite se da:

- je plinski ventil zatvoren
- je električni spoj pravilno izveden. Provjerite je li zeleno/žuto uzemljenje spojeno pravilno na odgovarajući sustav uzemljenja
- kanal ispuha izgaranja treba biti prohodan;

2. Uključite uređaj (pritiskom ON/OFF dugmeta)

3. Otvorite ventil kućne vode

4. Uređaj pokazuje grešku zaključavanja paljenja

5. Zatvorite ventil kućne vode

6. Da biste vratili postavke pritisnite ON/OFF na uređaju

7. Otvorite plinski ventil i provjerite brtve na spojevima, uključujući spojeve uređaja, provjerite da mjerač ne detektira nikakav prolaz plina. Eliminirajte curenja.

8. Pokrenite uređaj otvaranjem kućne vode.

First ignition

The first start-up must be carried out by a qualified technician.

1. Make sure that:

- The gas valve is closed;
- The electrical connection has been properly carried out. Make sure that, in any case, the green/yellow earthing wire is connected to an efficient earthing system;
- The exhaust duct for combustion products should be suitable and free from any obstructions;

2. Switch on the appliance (by pressing the ON/OFF button)

3. Open a D.H.W. tap.

4. The appliance indicates the ignition lock failure

5. Close the D.H.W. tap.

6. To Restore the system, switch ON/OFF the appliance.

7. Open the gas valve and check the connection seals, including the appliance connection seals, making sure that the meter does not detect any passage of gas. Eliminate any leaks.

8. Start the appliance by opening a D.H.W. tap.

UPOZORENJE!!

Voda s temperaturom većom od 50 ° uzrokuje ozbiljne opekotine.

Uvijek provjerite temperaturu vode prije uporabe.

**UPOZORENJE!!**

Ne koristite aparat bez vode.

**WARNING!!**

Water with a temperature higher than 50° cause serious burns.

Always verify water temperature before use.

**WARNING!!**

Do not use the appliance without water.



Regulacija plina

Checking the gas settings

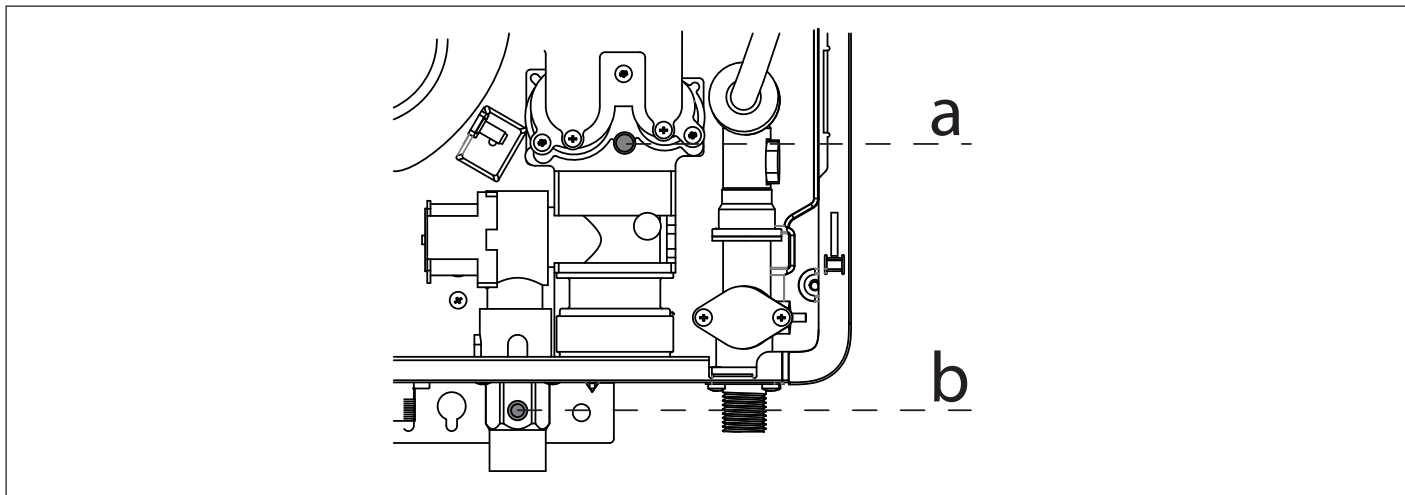

Provjera opskrbe tlaka

1. Zatvorite plinski ventil.
2. Otpustite vijak "b" i umetnite spojnu cijev mjerača tlaka u slavinu cijevi.
3. Otvorite plinski ventil.
4. Uključite aparat tako da otvorite slavinu kućne vode. Tlačni dovod treba odgovarati vrijednosti utvrđenoj u odnosu na vrstu plina za koju je uređaj namijenjen.

Supply pressure check

1. Close the gas valve.
2. Loosen screw "b" and insert the pressure gauge connection pipe into the pipe tap.
3. Open the gas valve.
4. Switch the appliance ON by opening a DHW tap. The supply pressure should correspond to the value established in relation to the type of gas for which the appliance is designed.

UPOZORENJE!

Ako tlak snage ne odgovara onome što je navedeno na tablici sažetka plina, NEMOJTE AKTIVIRATI UREĐAJ.



WARNING!!





Should the power pressure not correspond to what indicated on the Gas Summary Table, DO NOT ACTIVATE THE DEVICE.







5. Isključite aparat zatvaranjem slavine kućne vode.
6. Zatvorite plinski ventil.
7. Nakon završetka provjere, zategnite vijak "b" i pazite da je čvrsto na mjestu.
8. Otvorite plinski ventil i provjerite nepropusnost vijka.



5. Switch the appliance OFF by closing the DHW tap.
6. Close the gas valve.
7. When the check is over, tighten screw "b" and make sure it is securely in place.
8. Open the gas valve and check the tightness of the screw.

Provjera maksimalnog i minimalnog tlaka (pogledajte tablicu za podešavanje plina)





1. Zatvorite plinski ventil.
2. Otpustite vijak "a" i umetnite cijev za spajanje manometra u slavinu cijevi.
3. Otvorite plinski ventil.
4. Pritisnite dugme ON/OFF, zaslon će svijetliti.
5. Otvorite ventil tople vode i simultano pritisnite (2)  i  tijekom 5 s, na zaslonu piše **26**
6. Pritisnite ON/OFF, uređaj je na maksimalnoj snazi. Zaslon pokazuje broj od "00" do "99".
7. Na manometru provjerite pritisak i ukoliko je potrebno prilagodite maksimalni pritisak plamenika pritiskom na tipke (2)  i  kako je naznačeno u postavkama plina.



Checking the maximum and minimum pressure (see the Gas setting table)

1. Close the gas valve.
2. Loosen screw "a" and insert the manometer connection pipe into the pipe tap.
3. Open the gas valve.
4. Press the On/Off button the display will illuminate.
5. Open one hot water tap. Simultaneously press the  and  (2) buttons for 5 seconds. The display shows **26**.
6. Press the On/Off, appliance forced to maximum power. The display shows a number from "00" to "99".
7. On the manometer verify the pressure and if necessary press the the  and  (2) buttons to adjust maximum burner pressure as indicated on the gas settings table.





8. Pritisnite dugme ON/OFF, uređaj prisiljen na minimalnu snagu. Zaslom pokazuje broj od "00" do "99".
9. Na manometru provjerite tlak i po potrebi pritisnite tipke (2)  i  za podešavanje minimalnog tlaka plamenika kako je navedeno na tablici podešavanja plina.
10. Pritisnite dugme ON/OFF za potvrdu.
11. Zatvori slavinu s toplom vodom. Isključite uređaj putem tipke za ON/OFF.
12. Zategnite čvrsto vijak priključka i provjerite ima li curenja odgovarajućim uređajem

Provjera sporog paljenja (pogledajte tablicu za podešavanje plina)

1. Zatvorite plinski ventil.
2. Otpustite vijak "a" i umetnite cijev za spajanje manometra u slavinu cijevi.
3. Otvorite plinski ventil.
4. Pritisnite dugme ONN/OFF, zaslon će svijetliti.
5. Odspojite i ponovo spojite napajanje.
6. Simultano pritisnite tipke (2)  i  Na zaslonu piše **L6**. Uređaj radi na maksimalnoj snazi. Otvorite ventil tople vode.
7. Na manometru provjerite pritisak i ako je potrebno pritisnite (2)  i  kako bi prilagodili pritisak sporog paljenja kako je naznačeno u tablici plinova
8. Pritisnite dugme ON/OFF za spremanje postavki
9. Zatvorite ventil tople vode. Ugasite uređaj pritiskom na ON/OFF.
10. Zatvorite ventil tople vode. Ugasite uređaj pritiskom na ON/OFF.
11. Stegnite vijak spoja i provjerite ima li curenja.

8. Press the On/Off, appliance forced to minimum power. The display shows a number from "00" to "99".
9. On the manometer verify the pressure and if necessary press the the  and  (2) buttons to adjust minimum burner pressure as indicated on the gas settings table.
10. Press the On/Off button to confirm.
11. Close Hot water tap. Switch off the appliance through ON/OFF button.
12. Tighten the connector screw tightly and check for leaks using a suitable device

Checking slow ignition power (see the Gas setting table)

1. Close the gas valve.
2. Loosen screw "a" and insert the manometer connection pipe into the pipe tap.
3. Open the gas valve.
4. Press the On/Off button the display will illuminate.
5. Disconnect and reconnect the power supply.
6. Press simultaneously press the  or  (2) buttons for 3 seconds. The display shows **L6**, ppliance forced to ignition power. Open one hot water tap.
7. On the manometer verify the pressure and if necessary press the  or  (2) buttons to adjust the slow ignition pressure as indicated on the gas settings table.
8. Press the ON/FF button to save the change.
9. Close Hot water tap. Switch off the appliance through ON/OFF button.
10. Close Hot water tap. Switch off the appliance through ON/OFF button.
11. Tighten the connector screw tightly and check for leaks using a suitable device

Tablica postavki plina

Gas setting table



| | | NEXT EVO X SFT 11 | | | NEXT EVO X SFT 16 | | |
|--------------------------------------------------------------------------------------------------------|-------------------|-------------------|-------------|-------|-------------------|-------------|-------|
| | | G20 | G30 | G31 | G20 | G30 | G31 |
| Wobbe indeks- a (15°C, 1013 mbar) Indice Wobe inf. (15°C; 1013 mbares) | MJ/m ³ | 45.67 | 80.58 | 70.69 | 45.67 | 80.58 | 70.69 |
| Nazivni tlak napajanja Pressão nominal de alimentação | mbar | 20 | 28-30 | 37 | 20 | 28-30 | 37 |
| Tlak ispuha plina MAX Presiune la ieșire a valvei de găs MAX | mbar | 12.10 | 12.60 | 15.90 | 10.10 | 10.00 | 12.50 |
| Tlak ispuha plina MIN Presiune la ieșire a valvei de găs MIN | mbar | 3.0 | 3.0 | 3.0 | 2.5 | 2.5 | 2.5 |
| Tlak polakog paljenja Presiune de ligação lenta | mbar | 7.3 | 7.4 | 10.4 | 4.8 | 4.7 | 6.5 |
| Parametar L - kod kapaciteta uređaja Parameter L - appliance capacity code | nr. | 11 | 11 | 11 | 16 | 16 | 16 |
| Parametar q - kod tipa plina Parameter q - gas type code | | 12 | 22 | 19 | 12 | 22 | 19 |
| Parametr F- kod tipa uređaja Parameter F - appliance type code | | 0 | 0 | 0 | 2 | 2 | 2 |
| Broj mlaznica plamenika Bicos | nr. | 6X2 | | | 15x2 | | |
| Ø promjer mlaznica Ø Bicos (ø) | mm | 0.86 - 1.52 | 0.74 - 1.04 | | 0.74 - 1.28 | 0.62 - 0.88 | |
| Potrošnja maks./min. Consumos Max/min (15°C, 1013 mbar) (G.N.= m ³ /h) (LPG kg/h)) | MAX | 2.33 | 1.85 | 1.81 | 3.17 | 2.52 | 2.47 |

Izmjena plina

Uređaj se može namjestiti tako da se može koristiti s tekućim plinom (G30-G31) umjesto metanskog plina (G20) ili obrnuto.

Podešavanje mora obaviti ovlašteni serviser pomoću posebne opreme.

Da biste promijenili parametar, postupite kako slijedi:

1. Isključite uređaj, pritisnite dugme ON/OFF
2. Odspojite i ponovno priključite napajanje.
3. Pritiskom na tipke uzastopno, tijekom 3 sekunde
(2)  i , pristupite parametrima
4. Koristite ON / OFF, da biste pristupili parametrima promijenite ih i spremite izmjene



Parametri trebaju biti postavljeni kako je naznačeno u tablici dolje:

| | | NEXT EVO X SFT 11 | | | NEXT EVO X SFT 16 | | |
|-------------------------------------------------------------------------------|-----|-------------------|-----|-----|-------------------|-----|-----|
| | | G20 | G30 | G31 | G20 | G30 | G31 |
| Parametar L - kod kapaciteta uređaja Parameter L - appliance capacity code | nr. | 11 | 11 | 11 | 16 | 16 | 16 |
| Parametar q - kod tipa plina Parameter q - gas type code | | 12 | 22 | 19 | 12 | 22 | 19 |
| Parametar F: kod tipa uređaja Parameter F - appliance type code | | 0 | 0 | 0 | 2 | 2 | 2 |

Gas Changeover

The appliance may be adjusted so that it may be used with Liquid Gas (G30-G31) instead of methane gas (G20) or vice-versa. The adjustment must be performed by a Qualified Technician using the special Kit.

To modify the parameter proceed as follow:

1. Switch Off the appliance, press the on/OFF button
2. Disconnect and reconnect the power supply.
3. Presione las teclas 2  y  simultáneamente durante 3 segundos para acceder a los parámetros.
4. Use the ON / OFF key to access the parameters, modify the parameters and save the changes made.

The parameters must be set as shown in the following table:

Uvjeti za isključivanje uređaja

Uređaj je zaštićen od kvarova pomoću unutarnjih provjera koje provodi vanjska elektronička ploča, koji zaustavlja rad uređaja ako je potrebno.

U slučaju ovakvog zaustavljanja rada uređaja, pojavljuje se kod na zaslonu koji se odnosi na tip gašenja i razlog.

Isključite uređaj. Isključite plinski ventil, provjerite je li vanjski prekidač u poziciji OFF i kontaktirajte ovlaštenog servisera.

Tablica kodova grešaka

| Kod greške Error code | Opis Description | |
|--------------------------|---------------------------------------------------------------------------------------------------------------------|---------------------------------------------------------------------------------------------------------------------------------------------------------------------------------------------------------------------------------------------------------------------------------------------------------------------------------------------------------------------------------------|
| A1 | Neuspješno paljenje-nema plamena Ignition fails - No flame detected No flame after safety time(3 attempts) | - Plinski ventil zatvoren Gas valve closed Otvorite ventil i započnite proceduru paljenja Open the valve and follow the activation procedure - Provjerite elektrodu paljenja Check the ignition electrode - Provjerite detekcijsku elektrodu Check the detection electrode Pritisnite ON / OFF, kako biste ponovno pokrenuli sustav Press the ON/OFF to Reset |
| A2 | Pregrijavanje Overheating (overheat thermostat/thermo fuse) (95°C) | - Temperatura je viša od 95 ° C. A temperature higher than 95°C has been detected. Provjerite vodeni tlak Check the water pressure Pritisnite ON / OFF, kako biste ponovno pokrenuli sustav Press the ON/OFF to Reset |
| A3 | Blokada dimnih cijevi Flue pipe blockage | Verify the air intake/exhaust fumes duct Provjerite kanal za usisni / ispušni zrak Pritisnite ON / OFF, kako biste ponovno pokrenuli sustav Press the ON/OFF to |
| A4 | Dizanje plamena Flame lift (3 Times) during burning | Reset Pritisnite ON / OFF, kako biste ponovno pokrenuli sustav Press the ON/OFF to Reset |
| A6 | Temperatura vruće vode. otvoreni krug sonde ili kratki spoj Hot water temp. probe circuit open / short circuit | |
| A7 | Temperatura hladne vode. otvoreni krug sonde ili kratki spoj Cold water temp. probe circuit open / short circuit | |
| E6 | Plamen bez plina Flame detected without gas ignition | |
| E7 | Greška ventilatora Fan error | |

Appliance shut-off conditions

The appliance is protected from malfunctions by means of internal checks performed by the electronic P.C.B., which stops the appliance from operating if necessary.

In the event of the appliance being shut off in this manner, a code appears on the display which refers to the type of shut-off and the reason behind it.

Switch off the appliance. Make sure the external electric switch is in the OFF position, shut off the gas valve and contact a qualified technician.

Table summarising error codes

Upute za otvaranje kućišta i provođenje unutarnjeg pregleda

Prije izvođenja bilo kakvog rada na uređaju, isključite vanjski prekidač i zatvorite plinski ventil.

Da biste pristupili unutašnjosti uređaja, trebate:

- Otpustite 4 vijka
- Povucite prema naprijed i maknite

Instructions for opening the casing and performing an internal inspection

Before performing any work on the appliance, first disconnect it from the electrical power supply using the external bipolar switch and shut off the gas valve.

To access the inside of the appliance, the following is necessary:

- loosen the 4 screws,
- pull it forward and remove it.

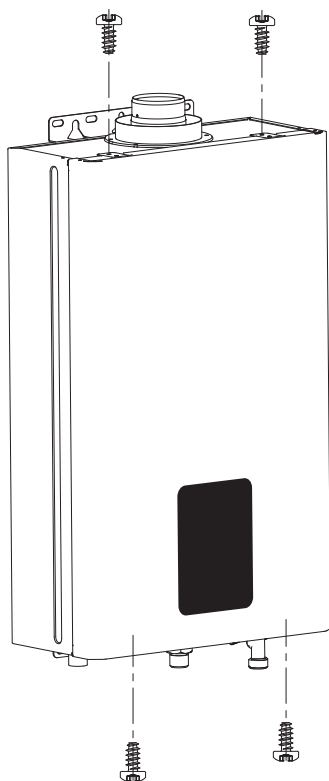

Održavanje je bitan dio sigurnog i učinkovitog rada uređaja i osigurava njegovu trajnost. Potrebno ga je izvršiti u skladu s važećim zakonima. Redovito provoditi analizu sagorijevanja kako bi se provjerila radna učinkovitost uređaja i osigurali da se sve nečiste tvari koje se ispuštaju nalaze u granicama propisanim važećim zakonodavstvom. Prije početka održavanja:

- Odspojite uređaj iz napajanja tako da okrenete vanjski bipolarni prekidač u položaj "OFF";
- Zatvorite plinski ventil i ventil za centralno grijanje i kućnu vodu.

Po završetku rada, početne postavke će se vratiti.

Općenito

Preporuča se da na uređaju provedete sljedeće preglede najmanje jednom godišnje:

1. Vizualno provjerite cjelokupno stanje uređaja
 2. Provjerite brtve u vodenom krugu i po potrebi zamijenite brtve i vratite ih u rad
 3. Provjerite brtve u plinskom krugu i po potrebi zamijenite brtve i vratite ih u rad
 4. Vizualno provjerite izgaranje i, ako je potrebno, rastavite i očistite plamenik.
 5. Nakon detaljnog pregleda u točki "3", rastavite i očistite komoru za izgaranje, ako je potrebno.
 6. Nakon detaljnog pregleda u točki "4", rastavite i očistite plamenik i mlaznicu, ako je potrebno.
 7. Čišćenje primarnog izmjenjivača topline
 8. Uvjerite se da sljedeći sigurnosni uređaji ispravno rade:
 - temperaturni limitator
 9. Pazite da sljedeći sigurnosni uređaji plina ispravno rade:
 - odsustvo osigurača plina ili plamena (ionizacija).
 10. Provjerite učinkovitost procesa proizvodnje tople vode u kućanstvu (ispitajte brzinu protoka i temperaturu).
 11. Čišćenje filtera u ulazu za hladnu vodu.
- UPOZORENJE! UREĐAJ SE NE SMIJE STAVLJATI U FUNKCIJU BEZ FILTRA.**
12. Izvršite opći pregled rada uređaja.
 13. Maknite oksid iz detekcijske elektrode koristeći brusni papir

Maintenance is an essential part of the safe and efficient operation of the appliance and ensures its durability. It should be performed according to the instructions given in current legislation. Perform combustion analysis regularly in order to check the operating efficiency of the appliance and to make sure any polluting substances released are within the boundaries set by current legislation.

Before beginning maintenance work:

- Disconnect the appliance from the electricity supply by turning the external bipolar switch to the "OFF" position;
- Close the gas valve and the central heating and domestic hot water system valve.

After the work has been completed the initial settings will be restored.

General comments

It is recommended that the following inspections be carried out on the appliance at least once a year:

1. Check the seals in the water part and, if necessary, replace the gaskets and restore the seal to perfect working order.
 2. Check the seals in the gas part and, if necessary, replace the gaskets and restore the seal to perfect working order.
 3. Visually check the overall condition of the appliance.
 4. Visually check the combustion and, if necessary, disassemble and clean the burner.
 5. Following the inspection detailed in point "3", disassemble and clean the combustion chamber, if necessary.
 6. Following the inspection detailed in point "4", disassemble and clean the burner and injector, if necessary.
 7. Cleaning the primary heat exchanger
 8. Make sure the following safety devices are operating correctly:
 - temperature limit safety device.
 9. Make sure that the following gas part safety devices are operating correctly:
 - absence of gas or flame safety device (ionisation).
 10. Controllo dell'efficienza della produzione di acqua sanitaria (verifica della portata e della temperatura).
 11. Cleaning the filter in cold water inlet.
- WARNING! THE APPLIANCE MUST NOT BE PUT IN FUNCTION WITHOUT FILTER.**
12. Perform a general inspection of the appliance operation.
 13. Remove oxide from the detection electrode using an emery cloth.

Proba rada

Nakon provedenih postupaka održavanja, napunite uređaj i vodeni krug vodom.

- Uključite uređaj
- Provjerite postavke i provjerite jesu li naredbe, podešavanja i prateći dijelovi ispravni
- Provjerite brtvu i da sustav za istjerivanje dima / usisavanje zraka za izgaranje radi ispravno.

Postupci drenaže

Sustav se mora drenirati na slijedeći način:

- Zatvorite ventil ulaza vode
- otvorite ventile tople i hladne vode
- ispraznite vodu s najnižih točaka u uređaju (gdje je primjenjivo)

UPOZORENJE

Prije rukovanja, ispraznite sve dijelove koji mogu sadržavati toplu vodu, ispuštajući vodu po potrebi.

Obrišite komponente u skladu s uputama navedenim u sigurnosnom letku s isporučenim proizvodom, provjerite je li prostorija dobro prozračena, nosite zaštitnu odjeću, izbjegavajte miješanje različitih proizvoda i zaštitite uređaj i okolne predmete.

Zatvorite sve otvore koji se koriste za mjerenje tlaka plina ili za podešavanje plina.

Provjerite je li mlaznica kompatibilna s isporučenim plinom. Ako se otkrije miris paljevine ili izlazi dim iz uređaja, ili osjetite miris plina, isključite iz struje, isključite plinski ventil, otvorite prozore i pozovite tehničku pomoć.

Informacije za korisnika

Obavijestite korisnika o načinu rukovanja uređajem.

Posebno, dajte korisniku upute za uporabu i obavijestite ga da ih je potrebno pohraniti uz uređaj. Osim toga, provjerite zna li korisnik slijedeće:

- Kako postaviti temperaturu i uređaje za podešavanje za pravilno i ekonomičniji rad uređaja.
- Sustav se mora redovito održavati u skladu s propisima.
- Postavke koje se odnose na opskrbu zrakom za izgaranje i plina za izgaranje ne smiju se ni u kom slučaju mijenjati.

Operational test

After having carried out the maintenance operations, fill the appliance and the water circuit.

- Begin operating the boiler.
- Check the settings and make sure all the command, adjustment and monitoring parts are working correctly.
- Check the seal and that the system for the expulsion of fumes/suction of comburent air is operating correctly.

Draining procedures

The system must be drained using the following procedure:

- Close the inlet water valve;
- Open the hot and cold water taps;
- Empty the water from the lowest points of the system (where applicable).

WARNING

Before handling, empty all components which may contain hot water, performing bleeding where necessary.

Descale the components in accordance with the instructions provided on the safety data leaflet supplied with the product used, make sure the room is well ventilated, wear protective clothing, avoid mixing different products, and protect the appliance and surrounding objects.

Seal all openings used to take a gas pressure reading or to make any gas adjustments.

Make sure that the nozzle is compatible with the supplied gas.

If a smell of burning is detected or smoke is seen leaking from the appliance, or there is a smell of gas, disconnect it from the electricity supply, shut off the gas valve, open the windows and call for technical assistance.

Information for the user

Inform the user on how to operate the appliance.

In particular, provide the user with the instruction manuals and inform him/her that these must be stored with the appliance.

Moreover, make sure the user is aware of the following:

- How to set the temperature and adjustment devices for using the appliance correctly and in a more cost-efficient way.
- The system must be serviced regularly in compliance with legislation.
- The settings relating to the supply of combustion air and combustion gas must not in any event be modified.

Simboli ta pločici uređaja

Symbols used on the data plate

Opis:

1. Marka
2. Model
3. Kod proizvođača
4. Broj homologacije
5. Kategorija plina
6. Nazivna snaga ulaznog grijanja max
7. Izlazna snaga grijanja max
8. Nazivna snaga ulaznog grijanja min
9. Izlazna snaga grijanja min
10. Stopa specifične brzine tople vode
11. Vrsta instalacije
12. Plinovi koji se mogu koristiti
- Maksimalni tlak topline za kućanstvo
- Minimalni tlak vruće vode u kućanstvu 15/16/17. Električni podaci
18. Serijski broj
19. Kod institucije
20. Zemlja odredište
21. Proizvođač

| |
|----|
| 1 |
| 2 |
| 3 |
| 4 |
| 5 |
| 6 |
| 7 |
| 8 |
| 9 |
| 10 |
| 11 |
| 12 |
| 13 |
| 14 |
| 15 |
| 16 |
| 17 |
| 18 |
| 19 |
| 20 |
| 21 |

Legend:

1. Brand
2. IGWH model
3. Commercial reference
4. Certification number
5. Gas category
6. Input rating nominal heating max
7. Power output heating max
8. Input rating nominal heating min
9. Power output heating min
10. DHW specific flow rate
11. Installation type
12. Gases which may be used
13. Max domestic hot water pressure
14. Min domestic hot water pressure
- 15/16/17. Electrical data
18. Serial number
19. Institution code
20. Destination country
21. Manufacturer

| Naziv: NEXT EVO X | Model name : NEXT EVO X | | | 11 SFT | 16 SFT |
|-------------------------------------------------------|------------------------------------------------------|-----|-------|---------------|---------------|
| Certi ikat CE | CE Certification (pin) | | | 0063CR7772 | |
| Tip | Type | | | C13 - C33 | |
| Kategorija plina | Gas category | | | I12H3B/P | |
| Nom. ulazno grijanje maks. | Maximum nominal heat input | | kW | 22.0 | 30.0 |
| Nom. ulazno grijanje min. | Minimum nominal heat input | G20 | kW | 7.8 | 8.9 |
| | | G30 | kW | 7.8 | 9.0 |
| | | G31 | kW | 7.8 | 8.0 |
| Nom. izlazno grijanje maks. | Maximum nominal heat output | | kW | 19.2 | 26.9 |
| Nom. izlazno grijanje min. | Minimum nominal heat output | G20 | kW | 6.8 | 7.5 |
| | | G30 | kW | 6.8 | 7.6 |
| | | G31 | kW | 6.8 | 6.8 |
| Temperatura kućanske vode maks. | Domestic hot water temperature maximum | | °C | 65 | 65 |
| Temperatura kućanske vode min. | Domestic hot water temperature minimum | | °C | 35 | 35 |
| Nominalni protok kućanske vode | D.H.W. Nominal flow rate | | l/min | 11 | 16 |
| Minimalni protok kućanske vode | D.H.W. minium flow rate | | l/min | 2.5 | 2.5 |
| Max pritisak vode | Water pressure maximum | | bar | 10 | 10 |
| Min pritisak vode | Water pressure minimum | | bar | 0.2 | 0.2 |
| Max protok plina | Maximum flue gas flow | | g/s | 15.77 | 24.02 |
| Min protok plina | Minimum flue gas flow | | g/s | 9.68 | 13.95 |
| Temperatura ispuha dima pri maks. nom. ulazu grijanja | Flue fumes temperature at Maximum nominal heat input | | °C | 158 | 120 |
| Temperatura ispuha dima pri maks. nom. ulazu grijanja | Flue fumes temperature at Minimum nominal heat input | | °C | 43 | 56 |
| Ø ispuha dima i usisa zraka | Ø Flue outlet & Air intake | | | 60/100 | 60/100 |
| | | | | | |
| Dimenzije | Dimensions | | | | |
| Visina | Height | | mm | 570 | |
| Širina | Width | | mm | 345 | |
| Dubina | Depth | | mm | 165 | 187 |
| | | | | | |
| Frekvencija el. napona | Power supply voltage/frequency | | V/Hz | 230/50 | 230/50 |
| Snaga potrošnje | Power consumption | | W | 29 | 44 |
| Unutarnji osigurač | Internal fuse | | | 3.15 | |
| Razred zaštite električnog sustava | Electric system grades of protection | | IP | X4D | |
| Minimalna temperatura prostorije | Minimum operating room temperature | | °C | +5 | |
| Suha masa | Dry weight | | Kg | 13 | 15 |

ErP podaci- EU 814/2013



ErP Data - EU 814/2013

| | | | | |
|------------------------------------|------------------------------------------|--------|----------------------------------|---------------|
| Model: | Model NEXT EVO X SFT | | 11 SFT | 16 SFT |
| Modeli ekvivalentni | Equivalent models list | | vidi ANEKS A (*) see Annex A (*) | |
| Prijavljeni profil | Declared load profile | | M | XL |
| Dnevna potrošnja struje Q_{elec} | Daily electricity consumption Q_{elec} | kWh | 0.044 | 0.065 |
| Dnevna potrošnja plina Q_{fuel} | Daily Fuel Consumption Q_{fuel} | kWh | 7.804 | 24.845 |
| Razina zvuka L_{WA} | Indoor Sound power level L_{WA} | dB | 58 | 63 |
| Emisija nitrogen oksida NO_x | Emission of Nitrogen Oxide NO_x | mg/kWh | 45 | 47 |

(*) Za popis ekvivalentnih modela, pogledajte Prilog A, koji je sastavni dio ovog priručnika za uporabu, ugradnju i održavanje.

(*) For the list of equivalent models refer to Annex A, that is an integral part of this User's, Installation and Maintenance manual.

KARTA PROIZVODA - EU 812/2013 - PRODUCT FICHE - EU 812/2013

| | | | | |
|-----------------------------------|---------------------------------------------|-----|--------------------------------------------------------------------------------------|--------------------------------------------------------------------------------------|
| Marka | Brand | |  | |
| Model: | Model: | | NEXT EVO X | |
| | | | 11 SFT | 16 SFT |
| Prijavljeni profil | Declared load profile | | M | XL |
| Klasa energetske učinkovitosti | Water heating energy efficiency class | |  |  |
| En. uč. grijanja vode η_{WH} | Water heating energy efficiency η_{WH} | % | 78.3 | 80.5 |
| Godišnja potrošnja struje AEC | Annual electricity consumption AEC | kWh | 10 | 14 |
| Godišnja potrošnja plina AFC | Annual fuel consumption AFC | GJ | 6 | 19 |
| Postavke temperaturnog termostata | Thermostat temperature setting | °C | 55 | 55 |
| Razina zvuka L_{WA} | Indoor Sound power level L_{WA} | dB | 58 | 63 |

VAŽNO !!

Proizvodi bez oznake pakiranja i pakiranja za grijače vode i solarne uređaje, zahtijevane Uredbom 812/2013, nisu namijenjeni za uporabu u ovom sustavu..

Realizacija tih sustava dopuštena je korištenjem opreme koda **3024085**. U kompletu se nalazi naljepnica i karta paketa.

IMPORTANT!!

The products, without package label and package fiche for water heaters and solar devices, required by Regulation 812/2013, are not intended for use in these system.

The realization of these systems is allowed using the kit code **3024085**. In the kit are included package label and fiche.



ITALIAN DESIGN

ARISTON THERMO CROATIA D.O.O.

Kovinska 4a, 10000 Zagreb

Tel.: 01 /7899 100 Fax.: 01/7899 105

www.ariston.com

info.hr@aristonthermo.com